

Audi

Engine

Management

Systems, Level One

Technician's Reference Guide

Course Number 941002

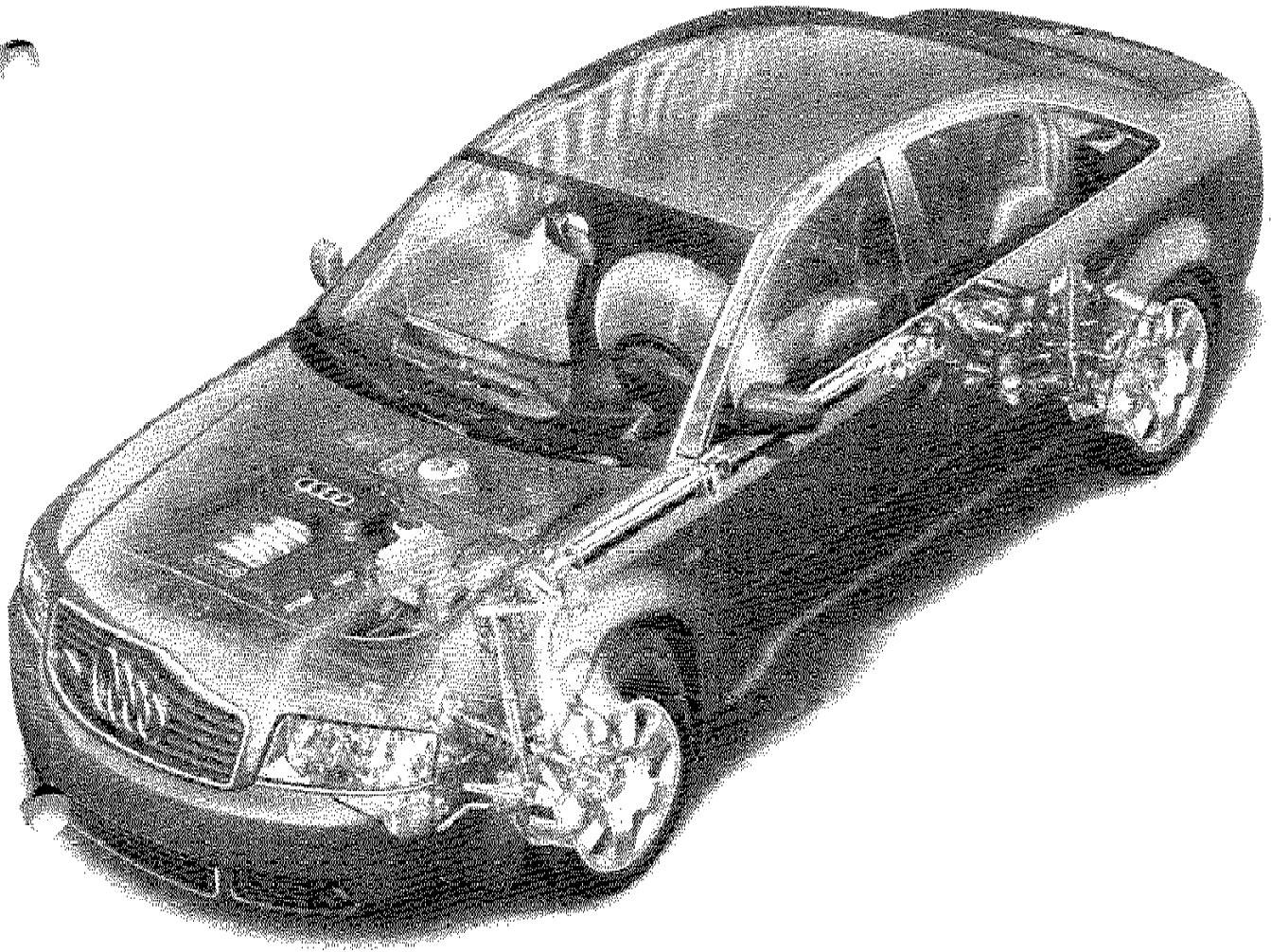

Table of Contents

Introduction	1
Learning objectives	2
Pretest Answer Sheet.....	5
Introduction to the Basics	11
Safety.....	21
AESIS functionality.....	23
Scan tool overview.....	24
Motronic System.....	25
Fault generation	31
Fuel Delivery	37
Ignition System	43
Mixture Control	45
Measuring Value Blocks	47
Emissions Systems	53
Readiness code.....	55
Turbocharger System	59
Post-test Answer Sheet.....	61

Learning Objectives

Learning Objectives

- Given access to a computer with AESIS installed, the technician will demonstrate proficiency in navigating through AESIS to locate and record procedures and specifications needed to perform diagnosis during all hands-on exercises throughout the course.
- Given a list of symptoms and test readings, the technician will demonstrate proficiency in "critical thinking" by diagnosing the most likely cause of a specific problem description.
- Given a vehicle with an electrical fault, AESIS, a VAG 1598 and a VAG1594, the technician will perform pin-out tests on specified circuits, compare his readings to specifications, and accurately determine readings that are out of specification.
- After participating in a classroom discussion on how faults are generated, including hard/ sporadic, range/performance, implausible signal, single trip, and miss-fire and random miss-fire, the technician will be able to diagnose 5 out of 7 faults set in the training vehicle, and document the steps to the instructor's satisfaction.

Learning Objectives

- After being instructed in class how to safely and effectively test fuel pressure and volume, the technician will, given the required tools (VAS 5051, VAG 1318 fuel pressure gauge w/ adapters, VAG 1602 graduated cylinders) and vehicle, perform fuel pressure and volume tests on a vehicle, and document all measurements.
- Given AESIS, hand tools, test equipment, and a vehicle with an evaporative emissions problem that lights the MIL, the technician will find the problem and document the test steps to the instructor's satisfaction.
- Given access to the VAS 5051, a test vehicle and hand tools, the technician will demonstrate his ability to scope a variety of signals, including oxygen sensors, camshaft position sensor, engine speed sensor, and the mass air flow sensor. He will then document and describe the captured signals.
- After participating in a classroom discussion on how the readiness code and the short trip monitor can be used for diagnosis, the technician will use the VAS 5051 to set the readiness code on a vehicle and diagnose system faults to the instructor's satisfaction.

Learning Objectives

- Given the VAS 5051 and a "bugged" test vehicle, the technician will call up measuring value block 000 and demonstrate/document how multiple value blocks (10 fields) relate to the problem.
- Given a multimeter, hand tools, and a task list, the technician will perform a voltage drop, a wiggle test, and a Ground circuit test to 100% accuracy.
- After participating in a classroom discussion regarding turbocharger operation, controls, and testing, the technician will be able to complete a shop exercise on monitoring the turbocharger system using the VAS 5051 and VAG 1397A turbocharger tester to the instructor's satisfaction.
- At the completion of the Engine Management Systems Level 1 course, the technician will score 80% or better on a final exam, consisting of true and false, multiple choice, and matching questions. This is required to receive credit for the course, and to fulfill the prerequisite for the Engine Management Systems level 2 course.

Pre-test Answer Sheet

Engine Management Systems Course # 941002 Pre-test Answer Sheet

Name: _____ Date: _____

Record the answers to the questions by blackening the letter of your choice for each question.
Fill in blanks where appropriate.
DO NOT CIRCLE THE LETTERS!

- | | | | | | | | | | |
|-----|-------------------------|-------------------------|-------------------------|-------------------------|-----|-------------------------|-------------------------|-------------------------|-------------------------|
| 1. | <input type="radio"/> A | <input type="radio"/> B | <input type="radio"/> C | <input type="radio"/> D | 14. | <input type="radio"/> A | <input type="radio"/> B | <input type="radio"/> C | <input type="radio"/> D |
| 2. | <input type="radio"/> A | <input type="radio"/> B | <input type="radio"/> C | <input type="radio"/> D | 15. | <input type="radio"/> A | <input type="radio"/> B | <input type="radio"/> C | <input type="radio"/> D |
| 3. | <input type="radio"/> A | <input type="radio"/> B | <input type="radio"/> C | <input type="radio"/> D | 16. | <input type="radio"/> A | <input type="radio"/> B | <input type="radio"/> C | <input type="radio"/> D |
| 4. | <input type="radio"/> A | <input type="radio"/> B | <input type="radio"/> C | <input type="radio"/> D | 17. | <input type="radio"/> A | <input type="radio"/> B | <input type="radio"/> C | <input type="radio"/> D |
| 5. | <input type="radio"/> A | <input type="radio"/> B | <input type="radio"/> C | <input type="radio"/> D | 18. | <input type="radio"/> A | <input type="radio"/> B | <input type="radio"/> C | <input type="radio"/> D |
| 6. | <input type="radio"/> A | <input type="radio"/> B | <input type="radio"/> C | <input type="radio"/> D | 19. | <input type="radio"/> A | <input type="radio"/> B | <input type="radio"/> C | <input type="radio"/> D |
| 7. | <input type="radio"/> A | <input type="radio"/> B | <input type="radio"/> C | <input type="radio"/> D | 20. | <input type="radio"/> A | <input type="radio"/> B | <input type="radio"/> C | <input type="radio"/> D |
| 8. | <input type="radio"/> A | <input type="radio"/> B | <input type="radio"/> C | <input type="radio"/> D | 21. | <input type="radio"/> A | <input type="radio"/> B | <input type="radio"/> C | <input type="radio"/> D |
| 9. | <input type="radio"/> A | <input type="radio"/> B | <input type="radio"/> C | <input type="radio"/> D | 22. | <input type="radio"/> A | <input type="radio"/> B | <input type="radio"/> C | <input type="radio"/> D |
| 10. | <input type="radio"/> A | <input type="radio"/> B | <input type="radio"/> C | <input type="radio"/> D | 23. | <input type="radio"/> A | <input type="radio"/> B | <input type="radio"/> C | <input type="radio"/> D |
| 11. | <input type="radio"/> A | <input type="radio"/> B | <input type="radio"/> C | <input type="radio"/> D | 24. | <input type="radio"/> A | <input type="radio"/> B | <input type="radio"/> C | <input type="radio"/> D |
| 12. | <input type="radio"/> A | <input type="radio"/> B | <input type="radio"/> C | <input type="radio"/> D | 25. | <input type="radio"/> A | <input type="radio"/> B | <input type="radio"/> C | <input type="radio"/> D |
| 13. | <input type="radio"/> A | <input type="radio"/> B | <input type="radio"/> C | <input type="radio"/> D | | | | | |

Pre-test Notes

Lined area for notes.

Introduction to the Basics

Role of engine management

Previous systems with dealt fuel and ignition separately. The purpose of the fuel system was to insure delivery of the correct air/fuel mixture. The ignition system's function was to insure delivery of a correctly timed and sufficiently strong spark to ignite the air/fuel mixture.

In the mid-1980's, engine management systems began to combine both fuel and ignition control to better control engine operation.

Today's engine management system controls the air/fuel mixture, ignition timing and emissions. Shared sensor technology allowed the signal from a temperature sensor, for example, to be used for several different functions.

Mixture control feedback through the use of oxygen sensors allowed more precise metering of the fuel.

Ignition system feedback through the use of knock sensors allowed optimum spark timing (feedback loops).

Digital data processing and micro-processor technology made it possible to take extensive operating information from sensors and other input sources, and convert it to program-map-controlled fuel injection and ignition data.

Today, technology enables engine management systems to control not only emissions and driveability, but to constantly optimize engine torque as well.

The illustration below shows how shared sensor technology has evolved from separate fuel and ignition systems, to a modern, combined engine management system.

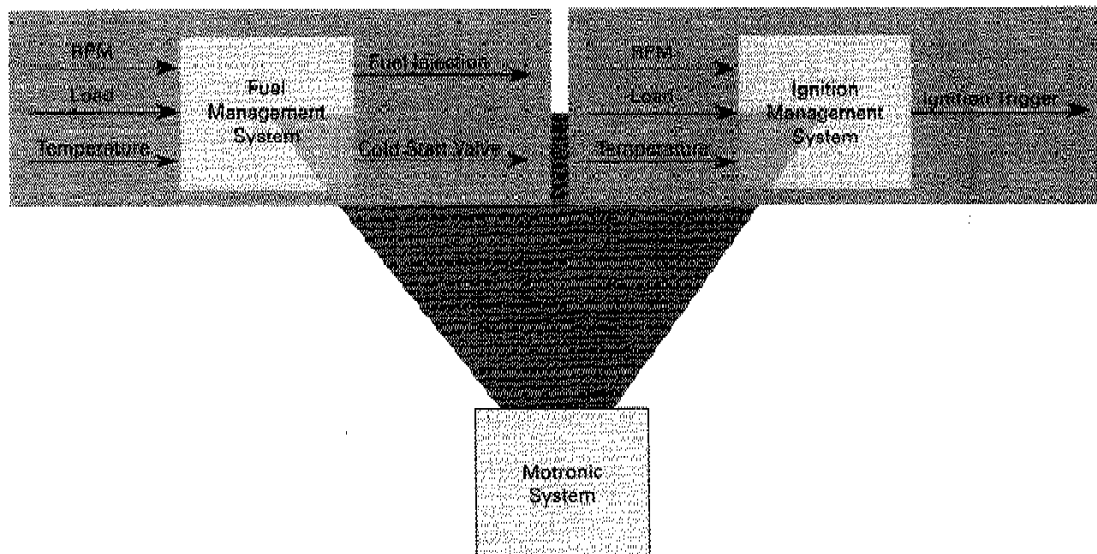

Introduction to the Basics

Four-stroke engine operation

An internal combustion engine requires the proper ratios of air and fuel, combined with a properly timed spark for efficient combustion.

Several support systems are required to make the combustion process occur continuously. The valvetrain operates the valves, the lubrication system supplies the oil, the cooling system regulates the operating temperature, and the electrical system supplies the voltage. The engine management system delivers fuel and spark to match the air demands of the engine.

The mechanical systems must all work together to draw the combustible mixture into the cylinder, to compress it, to extract maximum power from combustion and to expel what remains after the combustion process. These systems work together to provide the support necessary to keep the engine running.

If there is a mechanical malfunction in the engine, it will directly affect the operation and influence of the engine management system. A malfunctioning engine management system can also be mistaken for a mechanical engine malfunction.

To eliminate the possibility of a mechanical engine malfunction, cylinder leakdown, compression tests, and valve timing can be done to determine the internal condition of the engine. For more detailed information, refer to the *Audi Engine Management SSP #941003*, page 4.

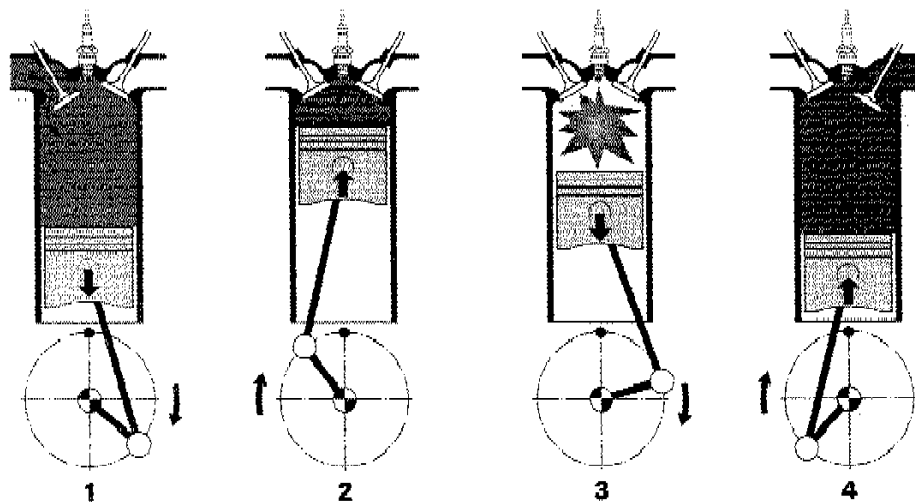

SSP 6410/00

Introduction to the Basics

Overview of Charge Air Path

For the engine management system to operate correctly, the supply of air must be consistent. The charge air path in a normally aspirated engine consists of the following components:

- Air inlet
- Air filter and housing
- MAF
- Air Intake Duct
- Throttle valve
- Intake manifold
- Ports and valves

The charge air path in a turbocharged engine consists of the following components:

- Air inlet
- Air filter and housing
- MAF
- Turbocharger
- Charge air cooler
- Air Intake Ducts
- Throttle valve
- Intake manifold
- Ports and valves

The illustration shown below follows the complete charge air path in a TT with a 1.8 liter turbocharged engine.

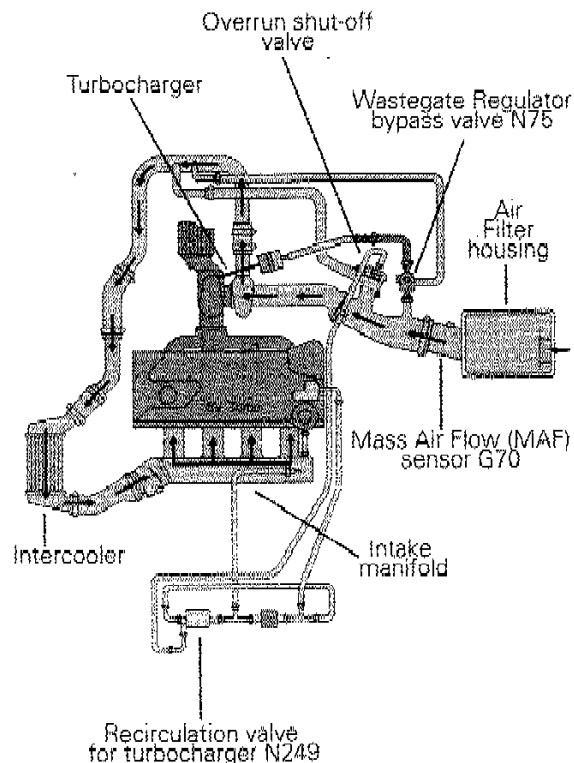

Introduction to the Basics

Variable intake manifold

Two multi-path intake manifolds were developed for the Audi V6 and V8 engines. The benefits of these styles of intake manifolds are high torque at low engine speeds, and increased power at higher RPM. Audi uses a **Two stage variable intake manifold** on the V6 engine and a **Three stage variable intake manifold** on the V8 4.2 Liter engine.

Two stage variable intake manifold

The two stage variable intake manifold on the V6 engine has six flaps (rotary change-over valves) that are opened and closed by a vacuum servo. They are closed up to 4100 RPM (longer path is open) for maximum torque and above 4100 RPM they open completely for higher power output. The servo is electronically activated by the Engine Control Module.

Long path: Long, narrower diameter intake manifold runners supply the combustion air at lower engine speeds to provide optimum torque.

Short path: Short larger diameter intake manifold runners ensure large volumes of air at high RPM for maximum performance.

The "Ram effect" is based on the principle that air moving through a longer but smaller diameter column will cause the velocity to rise. This quickly moving mass of air continues to fill the cylinder after the piston has reached Bottom Dead Center (BDC). As engine speed and intake air velocity increase, the narrow diameter of the intake tube restricts airflow. As a result a larger, shorter tube is used at higher engine RPMs.

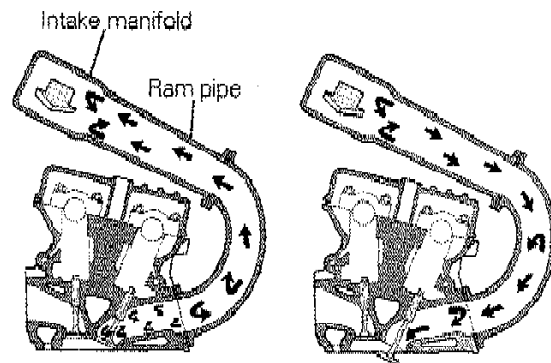
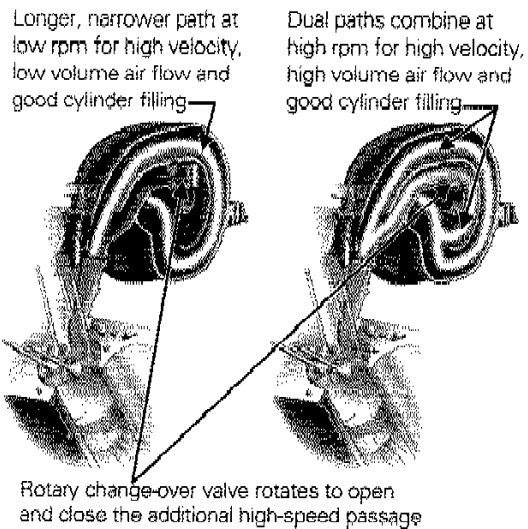

Introduction to the Basics

Three stage variable intake manifold

The three stage variable intake manifold is used on the V8 engine. The concept uses two intake manifold flaps to produce three different intake manifold lengths.

Stage 1: Lower speed range. When the engine is switched off, both flaps are open. If the engine is idling, the two vacuum units are evacuated by the appropriate intake manifold change-over solenoid valves. The intake manifold flaps are closed between idle speed and switching speed.

Stage 2: Middle speed range. Intake manifold change-over valve N156 allows atmospheric pressure into the vacuum unit of the stage 3 intake manifold flap. The stage 2 flap is opened, and the intake path is shortened.

Stage 3: Upper speed range. The stage 3 manifold flap is opened. The intake air takes the shortest path to the combustion chamber.

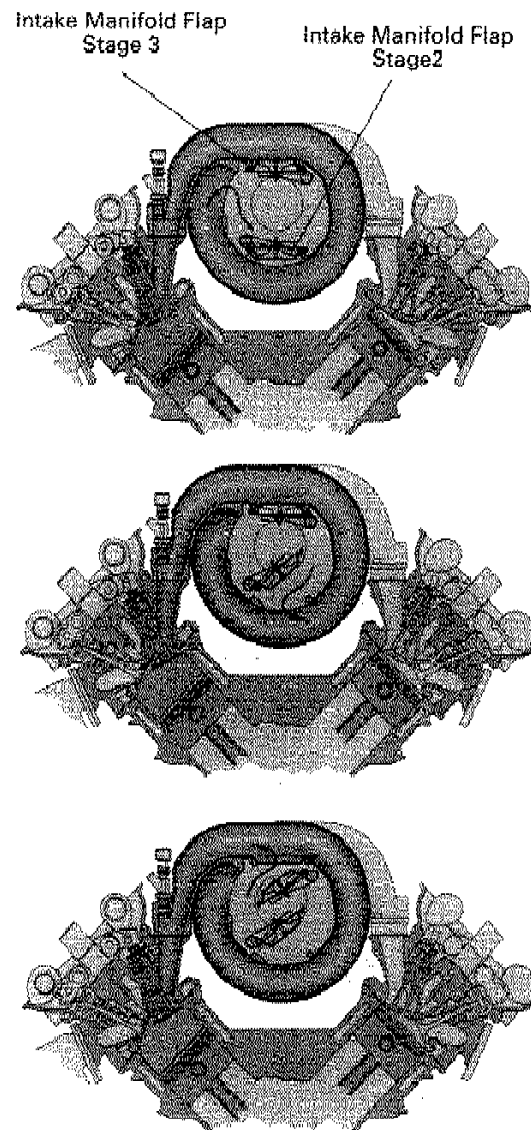

Introduction to the Basics

Turbocharger

Some engines use turbochargers to provide additional air. This additional air is mixed with additional fuel to provide greater power under some conditions.

Turbochargers compress the air, concentrating the heat in the air, raising its temperature. The hot air is directed through the charge air cooler (intercooler) where the heat is removed.

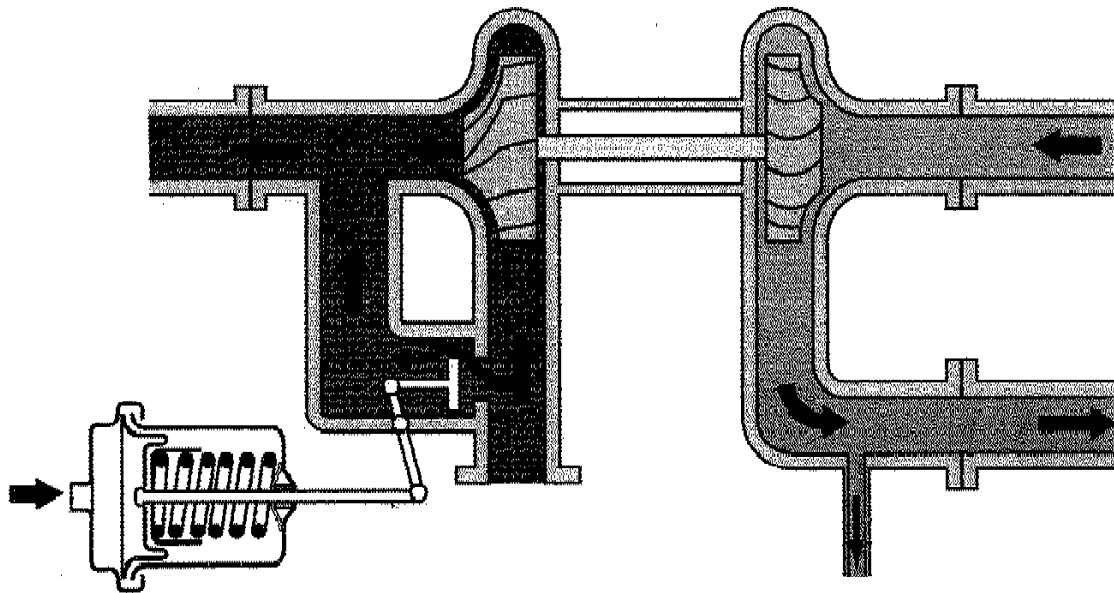

Introduction to the Basics

Fuel delivery

For the engine management system to operate correctly, the fuel must be delivered consistently. The fuel delivery system consists of:

- Fuel tank (including filler neck and vent system)
- Fuel pump
- Fuel filter
- Fuel pressure and return lines
- Fuel rail
- Fuel injectors
- Fuel pressure regulator

The fuel must be delivered with sufficient volume and pressure. The fuel pump must keep up with the varying demands of the engine's fuel requirements, and the fuel pressure regulator must maintain a constant fuel pressure in relation to manifold pressure.

Gasoline properties

For the engine management system to allow the engine to operate at peak efficiency and power, the gasoline used in the vehicle must meet required octane specifications.

Also, if gasoline sits for an extended period of time octane can evaporate from the fuel, and the resulting "varnished residue" can clog the fuel system. This can contribute to hard starting, reduced performance and driveability complaints.

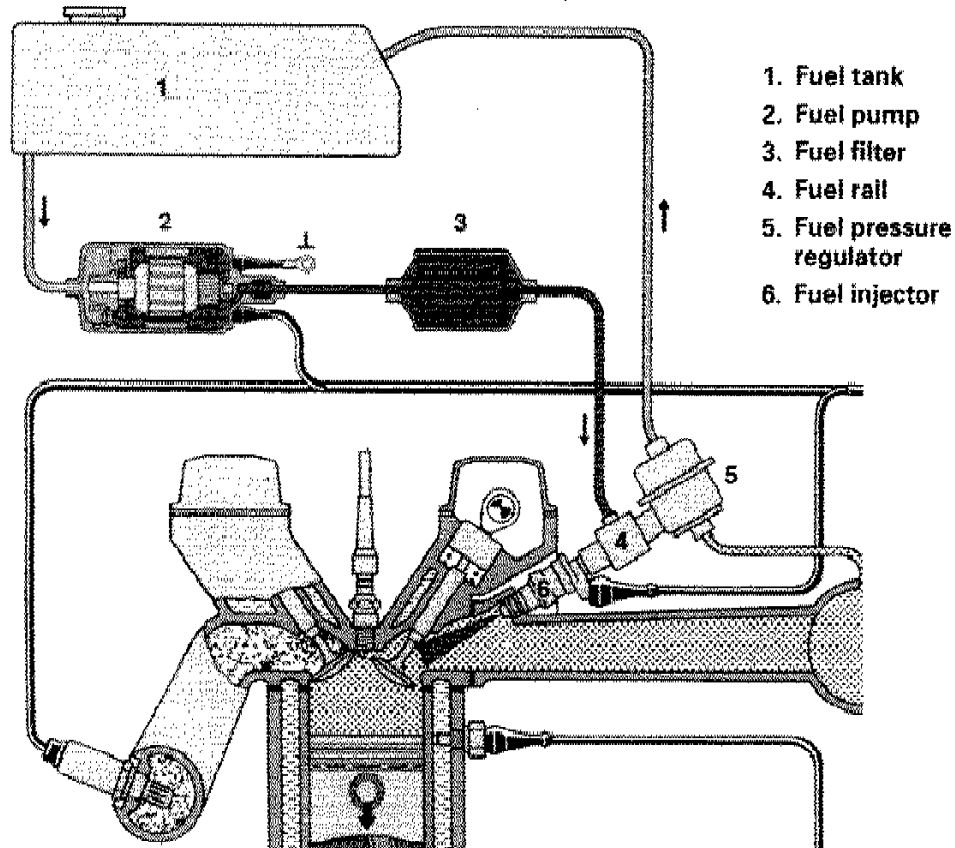

Introduction to the Basics

Fuel pressure regulator

When the engine is at idle, the manifold vacuum is high. When a fuel injector opens, fuel pressure forces the fuel out of the nozzle. Manifold vacuum also helps draw fuel out of the nozzle. As the throttle opens, manifold vacuum drops off, making less of a contribution to the quantity of fuel being injected. To compensate for this loss of fuel volume, the fuel pressure regulator must raise fuel pressure so that a consistent volume of fuel is delivered.

To ensure consistent fuel volume for any given injector pulse width, fuel pressure must vary with the changing manifold vacuum/pressure. For this reason, a manifold pressure line is attached to the top of the fuel pressure regulator.

Fuel pressure is controlled by a spring loaded diaphragm, closing off the port to the fuel return line. As the fuel pump pushes fuel into the fuel rail, the pressures rise to the point of lifting the diaphragm off the port, bleeding excess fuel pressure into the fuel return line. This maintains a constant pressure differential.

The chamber above the diaphragm and spring assembly connects to the intake manifold through a hose. When manifold vacuum is high (idle or deceleration), the vacuum is applied to the diaphragm in the fuel pressure regulator, working against the spring tension on top of the diaphragm. This causes the diaphragm to lift off the port at a lower fuel pressure. As manifold vacuum drops off on acceleration or cruise, fuel pressure increases.

Turbocharged engines

On turbocharged engines, as the system goes into boost, when the injector opens, there is manifold pressure opposing the fuel pressure. To overcome this resistance, the boost pressure is applied to the diaphragm and spring assembly to raise fuel pressure to counteracting the manifold pressure. Fuel volume remains constant for any fuel injector pulse width, regardless of manifold vacuum or pressure.

1. Intake-manifold connection
2. Spring
3. Valve holder
4. Diaphragm
5. Valve
6. Fuel supply
7. Fuel return

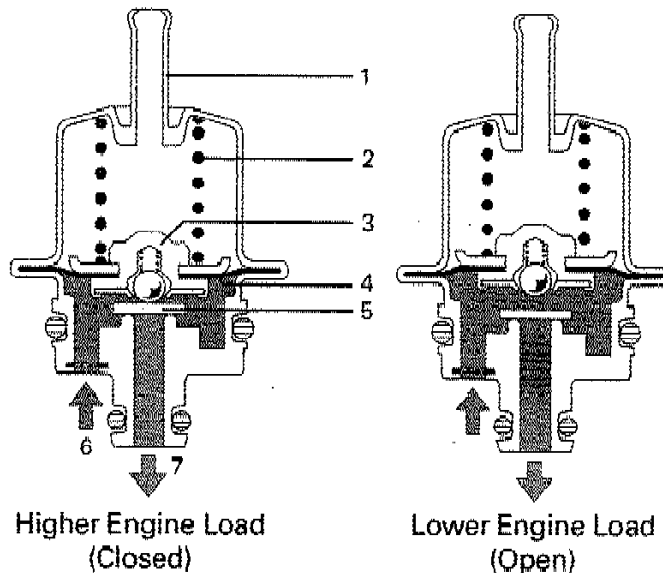

Introduction to the Basics

Air/fuel mixture formation

The function of the fuel system is to deliver the correct air/fuel mixture to the engine at all times. The optimal air/fuel ratio for complete combustion is 14.7 parts air to 1 part fuel by mass. This is referred to as the **stoichiometric ratio**.

The air/fuel mixture is referred to by the Greek letter λ (Lambda).

On an engine at normal operating temperature, it is important to maintain $\lambda = 1$. This allows for optimal catalytic converter operation.

Mixture corrections must be made by the engine management system as required to satisfy the differing engine demands encountered under any given driving condition.

Because of the importance of the fuel mixture under a variety of operating conditions, the air/fuel mixture must be adjusted constantly.

In modern systems, a feedback loop using oxygen sensors for the primary input is used for this adjustment.

The period of time after an engine start when the oxygen sensor is not at operating temperature, and therefore not used, is called **open loop operation**. This condition can occur after either a cold or warm start. Conversely, engine operation with a valid oxygen sensor signal is called **closed loop operation**.

For more information on open loop and closed loop operation, please refer to the *Audi Engine Management Systems SSP # 941003*, page 9.

Closed Loop Operation

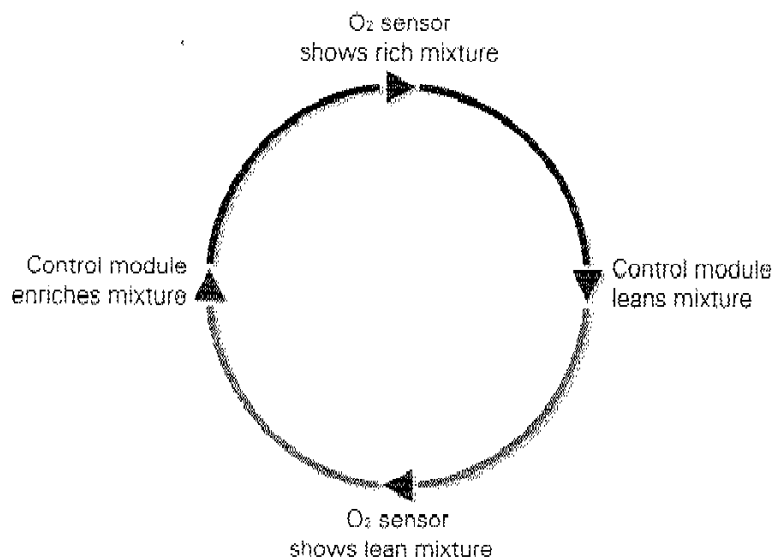

SSP 9410/08

Introduction to the Basics

Adaptation

All Audi engine management systems with an oxygen sensor adjust to changing conditions while the engine is running.

The ECM uses the oxygen sensor signal to determine the oxygen content of the exhaust gases. It then determines if the injector duration needs to be lengthened or shortened to achieve the optimum air/fuel ratio of 14.7: 1. This fine control range is referred to as **short term fuel trim**.

The Engine Control Module (ECM) contains information, or pre-programmed values, to control fuel mixture based on the oxygen sensor signal. Certain operating conditions, such as component wear or malfunction, unmetered air (leaks), and fuel pressure abnormalities extend beyond the ability of the sensor to control the air/fuel mixture. In this case, the ECM makes adjustments to the mixture based on the pre-programmed values. This coarse control range is referred to as **long term fuel trim, or adaptive learning**.

For more detailed information, refer to the *Audi Engine Management Systems* SSP # 941003, page 46.

System Adaptation - Balanced

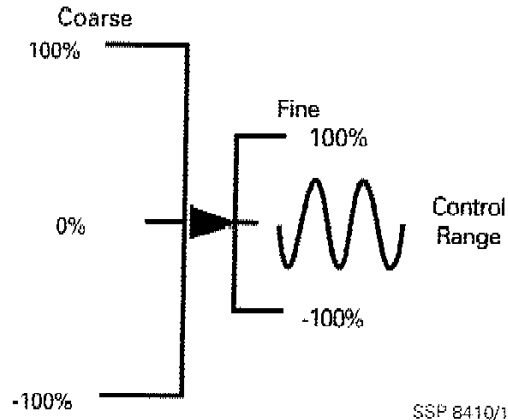

System Adaptation - Lean

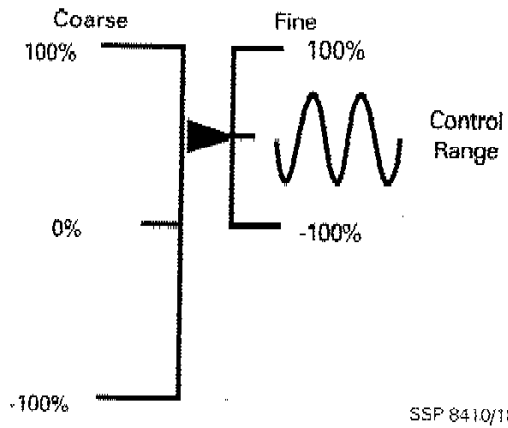

System Adaptation - Rich

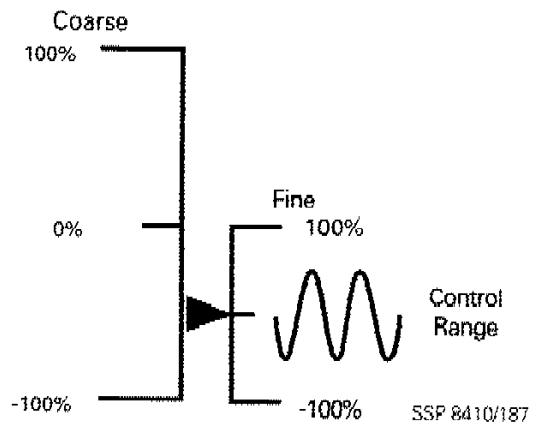

Introduction to the Basics

Ignition systems

The function of the ignition system is to ensure delivery of a correctly timed and sufficiently strong spark to ignite the air/fuel mixture.

Early systems were electro-mechanical using a mechanical switch (ignition points), while later systems substituted electronic in place of the points. Both of these systems use a mechanical distributor to insure delivery of the spark to the correct cylinder.

For more detailed information regarding the ignition system and spark plug functionality, refer to the *Audi Engine Management Systems* SSP # 941003, page 12.

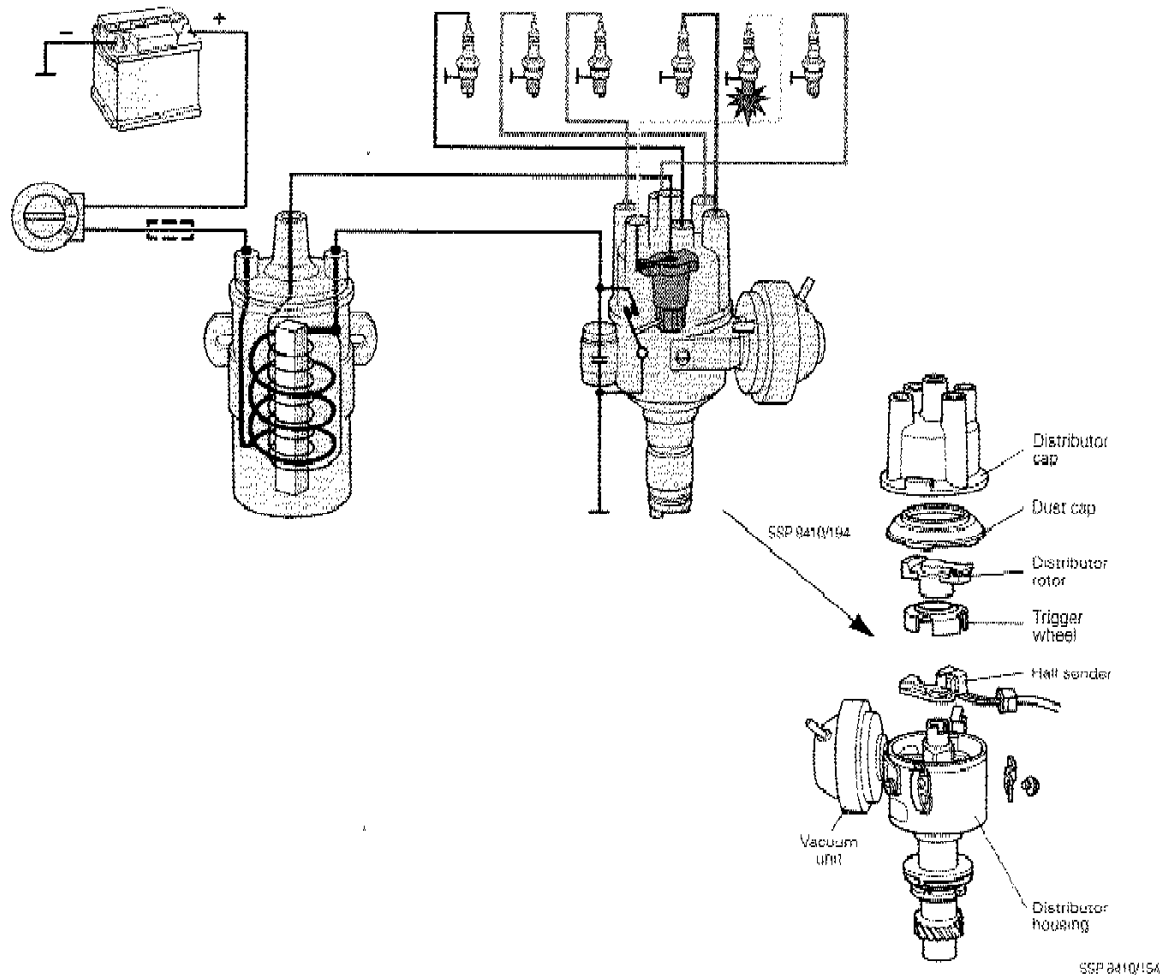

Introduction to the Basics

Emissions systems

The function of the emissions system is to minimize all unwanted vehicle emissions.

The following systems are all considered components of the emissions system:

- Evaporative Emissions (EVAP) (reduces Hydrocarbons [HC])
- Leak Detection Pump (LDP) (reduces Hydrocarbons [HC])
- Exhaust Gas Recirculation (EGR) (reduces Nitrogen Oxides [NO_x])
- On Board Refueling Vapor Recovery (ORVR) (reduces Hydrocarbons [HC])
- Secondary Air Injection (AIR) (reduces Hydrocarbons [HC] and Carbon Monoxide [CO])

- Three-Way Catalytic Converter (TWC) (reduces Hydrocarbons [HC], Carbon Monoxide [CO] and Nitrogen Oxides [NO_x])
- Positive Crankcase Ventilation (PCV) (reduces Hydrocarbons [HC])

Of the above systems, only EGR and EVAP directly contribute to the combustion process, where the other systems reduce emissions after combustion has occurred.

Maintaining Lambda within the operating window of between 0.97 and 1.03 results in minimum levels of Hydrocarbons [HC] and Carbon Monoxide [CO]. This represents the best compromise in overall performance vs. emissions (see graph below).

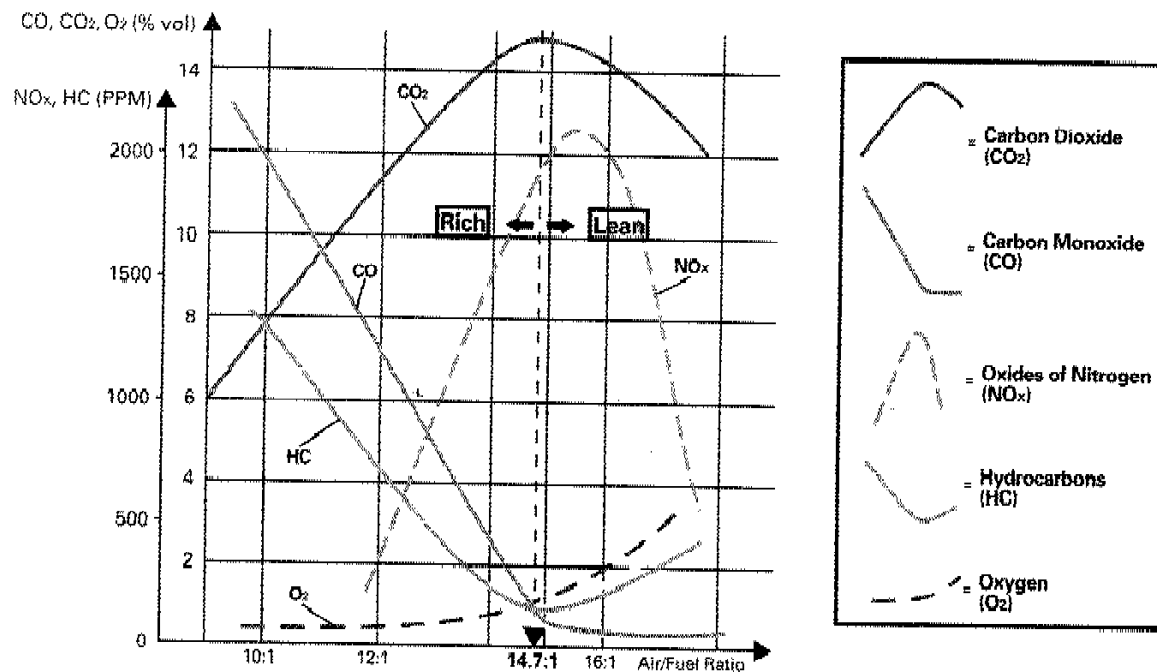

Introduction to the Basics

Oxygen sensors

Pre-catalyst oxygen sensors monitor combustion efficiency, and are located in the exhaust before the catalytic converter. Oxygen sensors measure the oxygen content of the exhaust to obtain an indication of instantaneous engine operation.

Post-catalyst oxygen sensors (OBD II) monitor catalytic converter efficiency, and are located in the exhaust at the outlet of the catalytic converter. Post-catalyst oxygen sensors measure the oxygen levels in the catalytic converter to obtain an indication of converter efficiency and condition. If the levels are out of specification, the post-cat sensor will illuminate the MIL.

Oxygen sensors must be at operating temperature to be accurate. Because the oxygen sensor needs to reach operating temperature quickly, a heating element is integrated into the sensor. This enables the temperature to be maintained despite changing operating conditions.

Catalytic converters

A Three-Way Catalytic (TWC) converter is so named because it takes the three major exhaust pollutants and changes them through reduction and oxidation. The pollutants are:

- NO_x (Oxides of Nitrogen)
- HC (Hydrocarbons)
- CO (Carbon Monoxide)

The output from a normally operating TWC consists primarily of:

- N_2 (Nitrogen)
- CO_2 (Carbon Dioxide)
- H_2O (Water)

These substances are much less harmful than untreated exhaust gas.

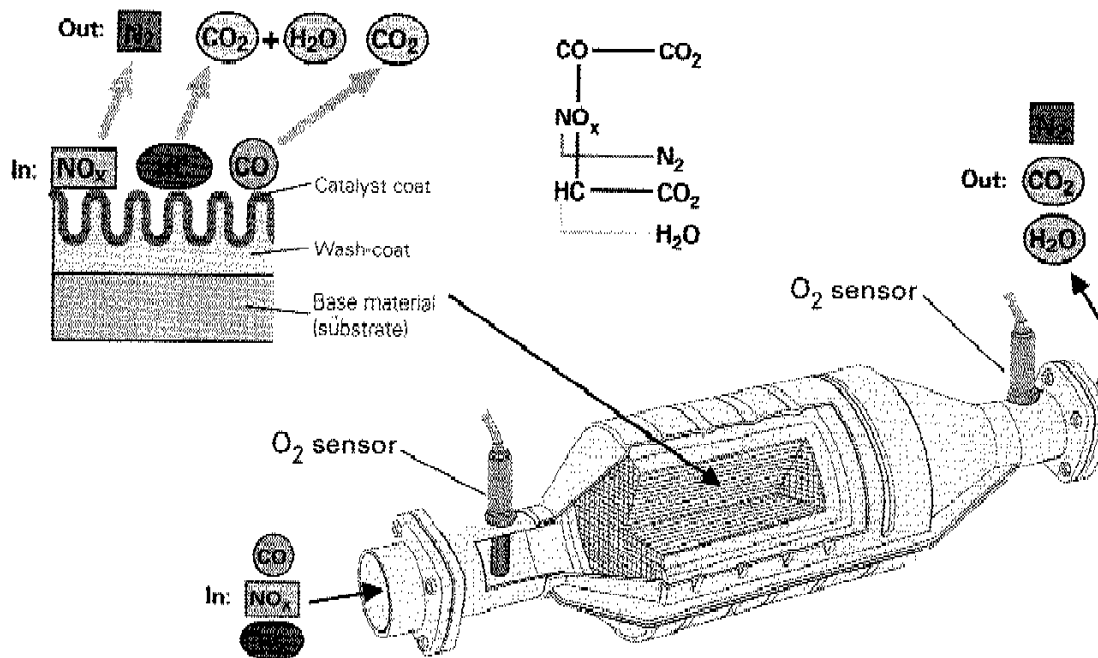

Introduction to the Basics

OBD II

Emissions reductions brought about as a result of OBD I technology evolved into the next generation of on board diagnostics, OBD II.

Beginning with the 1996 model year, all Audi passenger vehicles are equipped to meet the new OBD II diagnostic standard. OBD II is a refinement of the older OBD I standard. These new standards encompass more than engine operating parameters alone. Additional engine management components, engine and fuel systems, and non-engine systems are monitored as part of the OBD II system.

OBD II standards include:

- Standardized diagnostic connection and location in the driver's area
- Standardized DTCs for all manufacturers
- Retrieval of DTCs by commercially available diagnostic equipment (generic scan tools)
- Retention of operating conditions present during a monitored malfunction
- Standards governing when and how a monitored malfunction must be displayed
- Standardized names for components and systems

The monitored components and systems include:

- Three-way catalytic converter
- Oxygen sensors
- Engine misfire detection
- Secondary air injection
- Exhaust gas recirculation
- Evaporative emissions control and system integrity
- Fuel distribution system
- All sensors, components, and inputs associated with the ECM
- Automatic transmission (emissions-related functions)

For more detailed information regarding OBD II, refer to the *Audi Engine Management Systems SSP # 941003*, page 107.

Safety

Warnings and Cautions

Before proceeding with this course, a review of several possible hazards, along with safety precautions, is necessary. AESIS contains a comprehensive list of these safety precautions and warnings. In this section we will summarize some of them. Always consult AESIS for the specific Warnings and Cautions relating to the tasks you are performing.

On the AESIS control panel, within the row of vertical buttons, is a button with red text labeled **Warnings and Cautions** (see illustration below). When you select this option, Warnings and Cautions appear on screen. These items cover general shop and personal safety, as well as safety for specific systems and procedures.

Before starting a task or repair, always check the AESIS table of contents for Warnings and Cautions that are specific to that particular Repair Group. The illustration below shows the A6 Fuel Supply Safety Precaution screen, listing specific Warnings and Cautions relating to Fuel Supply.

For Warnings and Cautions relating to specific tasks, select applicable vehicle from vehicle screen, choose a system and Topic (Repair Group), then select the Safety Precautions topic from the Table of Contents. Not all Repair Groups list separate Safety Precautions. For those that do, always observe these extra precautions, in addition to the general items listed.

Safety precautions when working on the fuel supply system

WARNING!
Fuel supply pipes are under pressure! Before removing from hose connection wrap a cloth around the connection. Then release pressure by carefully pulling hose off connection.

When removing and installing the fuel gauge sender or fuel pump (fuel delivery unit) from a full or partly full fuel tank the following must be observed:

- Before commencing work, switch on exhaust extraction system and place an extraction hose close to the sender opening in the fuel tank to extract escaping petrol fumes. If no exhaust extraction system is available, a radial fan (as long as motor is not in air flow) with a displacement greater than 15 m³/h can be used.
- Prevent skin contact with fuel! Wear fuel-resistant gloves!

Navigation buttons on the right side of the screen:

- Vehicle
- System
- Repair Group
- Page Up
- Page Down
- Backtrack
- Technical Database
- Library
- Warnings/Cautions
- User Tools
- Help
- Exit
- Page: 26/29

Safety

Fuel System Safety

Gasoline is highly flammable. The attributes of gasoline that make it a good fuel for motor vehicles also makes it hazardous. Fuel system safety involves the following areas:

Fire protection

- Fuel supply lines are under pressure!
- When working on the fuel system, the battery ground strap should be disconnected. Where this is not possible (such as when checking fuel pressures), it is advisable to be prepared to quickly disconnect the ground strap.
- Never smoke when working on the fuel system, and never work near equipment with a pilot light (such as a shop heater or water heater).
- Use caution with drop lights. Broken incandescent bulb filaments can ignite spilled fuel and oil. Only approved designs with protected bulbs should be used.
- Always keep at least one inspected and approved fire extinguisher of the correct type handy and ready for immediate use.
- If a vehicle will be stored with an open fuel system, take appropriate precautions to insure that the fuel does not leak out, particularly if the vehicle is parked indoors.
- Use care with the storage of gasoline-soaked shop cloths due to the danger from spontaneous combustion. As with liquid gasoline, store only in containers designed for this purpose.

Eye protection

Eye protection is vital. Fuel splashed into the eyes can cause blindness.

- Always wear approved eye protection.
- Know the location of the nearest inspected and approved eyewash station before starting work on a fuel system.

Hand and skin protection

Fuel spilled onto exposed skin can be painful. Fuel sprayed onto the skin from high pressure sources (such as fuel injectors) can be forced through the skin and directly into the blood causing blood poisoning.

- Suitable hand protection should be worn at all times when working around fuel, particularly when working around fuel under pressure.
- Always wear appropriate clothing, such as shirts with long sleeves, aprons and other protective clothing

Breathing protection

Aside from the well-known dangers of carbon monoxide (CO) poisoning associated with engine operation, fuel vapors are also hazardous.

- Never work on any part of the fuel system in an enclosed area.
- Avoid breathing fuel vapors by working in a well-ventilated area. Never work in an enclosed area.
- Always use the shop exhaust and ventilation systems when running an engine inside a building.

Summary

Safety is an ongoing process involving many people. Take a few minutes and locate the hazards and safety devices mentioned. Look up, write down and post the phone numbers for the emergency services in your area. In many areas dialing 911 will bring assistance. Check your local area for specific numbers.

Being aware and being prepared can eliminate many hazards.

AESIS functionality

The Audi Electronic Service Information System (AESIS) could be the most valuable tool in your toolbox. AESIS is organized according to the same principles as the paper version of the Audi Worldwide Repair Information System.

The repair information is divided into:

- Repair Manuals
- Wiring Diagrams
- Technical Bulletins
- Suggested Repair Times
- Warnings and Cautions
- Component Locations

The three basic components of the AESIS display are:

- **Main Viewing Window:** displays repair information. The main viewing window is the white window that fills most of the screen.
- **Title Bar:** provides context for Repair Information. The title bar is located at the top of the screen.
- **Control Panel:** access to functions within AESIS. The Control Panel is located on the right-hand side of the screen. It is made up of buttons.

For information regarding AESIS navigation, refer to the *Audi Electronic Service Information System (AESIS) User Reference* booklet that is delivered with each subscription.

Updated CD-ROM sets containing new Repair Manual information and newly issued Technical Bulletins will be delivered approximately 4 to 6 times per year, as the volume of new data requires.

Throughout this class you will be using AESIS to identify component locations, wiring diagram info, Warnings and Cautions and specific diagnostic procedures.

User Notes

While in AESIS, it is possible to highlight the text in areas of interest and make notes within AESIS for future reference. For instance, while in the oxygen sensor section, you can highlight the words "oxygen sensor" and make a user note like "do not use silicone based lubricants to test the fuel system, or oxygen sensors can be damaged."

Refer to page 172 in the *Audi Engine Management Systems SSP # 941003* for specifics relating to:

- **Help Line/Tech tip line**
- **AESIS Feedback Form**

Discussion questions:

What are some of the ways you use AESIS at the dealership?

Have you ever called the HELP line?

Can you think of an error or omission in AESIS that if corrected could save someone time and energy during a repair?

Scan Tool Overview

Scan Tool (ST) overview

One of the most powerful troubleshooting tools available to the technician is the VAS5051 Vehicle Diagnostic Testing & Information System and the VAG1551 Scan Tool (ST). These scan tools can also operate as a "generic" scan tool using address word 33, though the preferred method of communication for Audi technicians is via address word 01.

The key to using the scan tool effectively is understanding all available operating modes and the menu structure. The following illustration outlines the VAG1551 scan tool menu structure, as well as that of the generic scan tool.

Note:

Address word 33 allows access to the generic scan tool function of the VAG1551 or VAS5051, and allows for several expanded functions.

One of the most helpful functions is access to "Freeze Frame" data. This data documents the exact operating conditions under which a Diagnostic Trouble Code (DTC) is stored.

Additional address words affecting the engine management system:

- Automatic Transmission, address word 02
- Air Conditioning, address word 08
- Anti-lock brakes, address word 03
- Comfort & Convenience, address word 46
- Airbag (crash signal to disable fuel pump), address word 15
- Instrument Cluster, address word 17
- CAN-Bus, address word 19

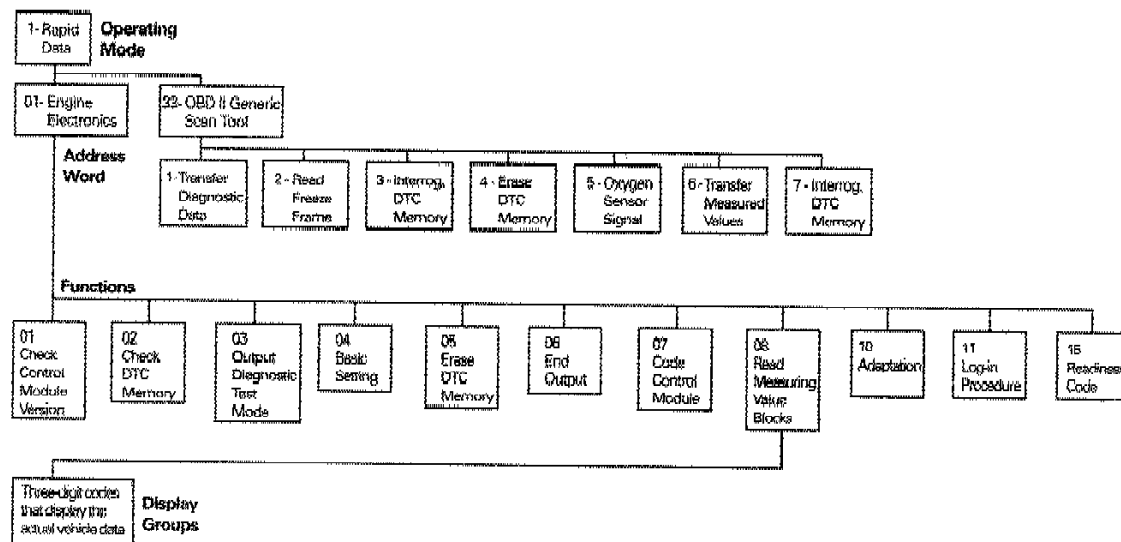

Motronic System

Learning Objectives:

- Identify and locate Motronic system components using AESIS.
- Review VAG1551 scan tool and generic scan tool functionality and menu structure.
- Monitor specific Motronic component signals using VAS5051(DSO) with VAG1598/31, VAG1551, multimeter.
- Understand relationship between all Motronic components and the engine management system.

Motronic sensors and actuators

ECM inputs (M5.9 and ME 7)

- Mass Air Flow (MAF) sensor
- Engine Speed (RPM) sensor
- Camshaft Position (CMP) sensor
- Engine Coolant Temperature (ECT) sensor
- Intake air temperature sensor
- Charge air pressure sensor (ME 7 only)
- Additional signals from other systems

ECM outputs

- Fuel injector
- Fuel pump relay
- Ignition primary switching
- EVAP canister purge regulator valve
- Intake manifold change-over valve
- Secondary Air Injection (AIR) relay
- Secondary Air Injection (AIR) solenoid valve
- Charge air pressure regulator valve
- Re-circulating valve for turbocharger

Combination systems

- Electronic throttle control
 - Accelerator pedal module
 - Throttle valve control module J338
 - ME 7 throttle angle sensors
 - ME 7 throttle angle motor
- Leak detection pump

Additional signals

The Motronic ECM also receives inputs from and provides inputs to other system control units. This interaction is illustrated below.

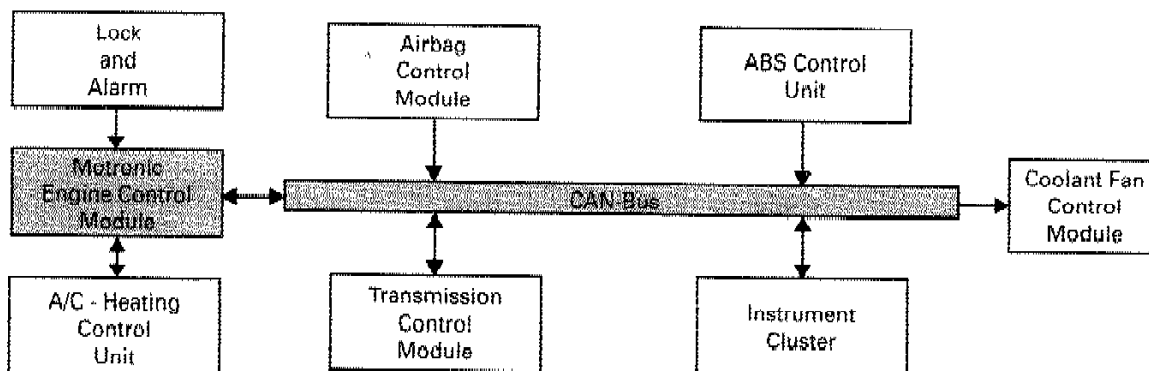

Motronic System

Sensors

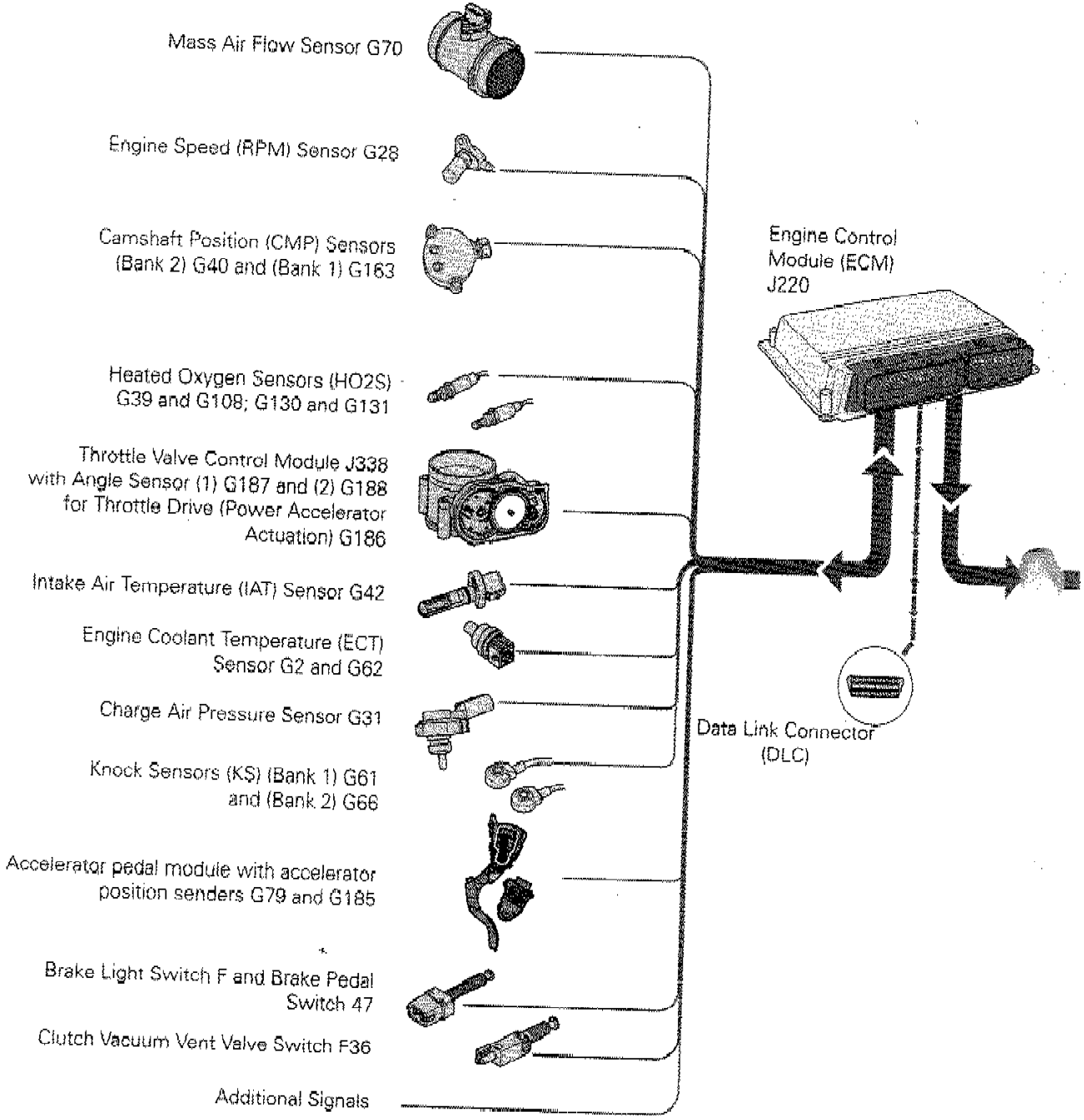

SSP 8420/08

Motronic System

Actuators

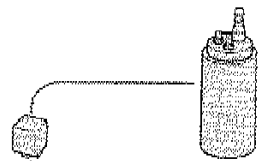

Fuel Pump (FP) Relay J17 and
Fuel Pump (FP) G6



Fuel injectors N30, N31, N32, N33

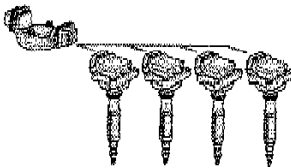

Power Output Stage N122 and Ignition Coils
N (Cyl. 1)
N128 (Cyl. 2)
N158 (Cyl. 3)
N163 (Cyl. 4)

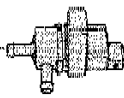

EVAP Canister Purge Regulator Valve N80



Wastegate Bypass Regulator Valve N75

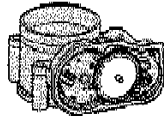

Throttle Valve Control Module J338
with Throttle Drive (Power Accelerator
Actuation) G186

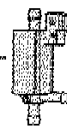

Recirculating Valve for Turbochargers N249



Oxygen Sensor (O2S) Heaters
Z19 and Z28; Z29 and Z30



Fault Light for Electronic Throttle
Control K132

Additional Signals

SSP 8420/08

Motronic System

System Authority

Contrary to popular belief, the oxygen sensor is not always responsible for a fuel mixture problem.

Actually, injector on-time is primarily a function of both RPM and air flow. RPM determines the frequency of injection, and air flow determines the duration of the injector pulse. Although other sensors have an affect on mixture, RPM and air flow have the greatest influence during almost all operating conditions.

Under certain operating conditions, specific sensors have a greater influence on the air/fuel mixture. To diagnose a malfunction properly, it is critical that the technician knows which sensors have the greatest authority during each operating condition. By analyzing the operating condition relating to the malfunction, you can save time and maximize your troubleshooting effort.

The operating conditions are as follows:

Open loop

In open loop the engine is cold, and the oxygen sensor is not yet up to operating temperature. During open loop the coolant temperature has greater authority than other sensors in the system.

Closed loop

When the oxygen sensor is up to temperature and operating properly, the system goes into closed loop operation. The oxygen sensor maintains the fuel mixture at 14.7:1 by increasing and decreasing injector on time, but does not necessarily have the greatest influence on fuel flow.

Warm up enrichment

The engine coolant temperature sensor and the intake air temperature sensor control warm up enrichment (cold operation).

Before the engine is at operating temperature the injector pulse will increase to enrich the mixture. As the engine warms up, the injector pulse decreases. At normal operating temperature there is no need for fuel mixture correction.

If a warm-up driveability problem exists, pay particular attention to the engine coolant temperature and intake air temperature sensors.

Acceleration enrichment

The signals from the throttle position sensor affect enrichment. This enrichment prevents hesitation at initial acceleration.

Deceleration (injector cutoff)

During deceleration (engine braking), the throttle position sensor sends a signal to the ECM, shutting off fuel delivery to the cylinders.

Idle/cruise

Although the accelerator pedal position has authority over the air/fuel mixture during conditions of low or stable engine loads (idle or cruise), the oxygen sensor has the highest priority.

Complete the table on the next page during the discussion on system authority in class.

Motronic System

System Authority for Engine Management

Condition	Loop: Open/Closed	Base Injector Pulse Width	Greatest Authority	Some Authority
Cold Start	open	MAF/RPM	ECT	IAT
Warm-up	Closed	"	ECT	IAT/HO ₂ S
Warm idle	Closed	"	HO ₂ S	ECT
Warm Cruise	Closed	"	HO ₂ S	TPS
Warm WOT	open/ closed	"	TPS	(HO ₂ S)
Acceleration	open/ closed	"	TPS	(HO ₂ S)
Deceleration	open/ closed	"	TPS/CTP VSS	(HO ₂ S)

Notes:

Motronic Review Notes

Sensors	Identifyr	Location/notes
Cam Position Sensor		
Recirc Valve For LRT		
Brake Sw.		
Injectors N30, N31, N32, N33		
LD Pump		
Cam Position Sensor	G40	Left Bank (Bank 2), G163 Bank 1
Recirc Valve For LRT	N249	
Brake Sw.	F47P	
Injectors	N30, N31, N32, N33	

Fault Generation

Learning Objectives:

- Given a list of symptoms and test readings, the technician will demonstrate proficiency in "critical thinking" by diagnosing the most likely cause of a specific problem description.
- After participating in a classroom discussion on how faults are generated, including hard/ sporadic, range/performance, implausible signal, single trip, and miss-fire and random miss-fire, the technician will be able to diagnose 5 out of 7 faults set in the training vehicle, and document the steps to the instructor's satisfaction.

Engine Control Module (ECM) fault recognition

Audi engine management systems have the ability to diagnose and identify the following failure conditions:

- High input
- Low input
- Implausible signals

ECM inputs (sensors) and outputs (actuators) are powered in one of two ways:

- The ECM supplies a ground signal and the B+ is supplied from the fuse/relay panel.
- The ECM provides a reference voltage and monitors the voltage drop across the sensor's resistance (e.g. engine coolant temperature sensor).

The Motronic ECM monitors component functionality by measuring the voltage drop across the component.

Each sensors operational voltage range is found within the total voltage range of the sensor. In the graphic below, the total voltage range of the sensor is 5 Volts, and the normal operating range of the sensor is between .5 Volts and 4.5 Volts. When the control module measures a signal that is outside of the normal operating range a Diagnostic Trouble Code (DTC) is set.

Note:

Voltage thresholds discussed here for DTC generation may vary, and are used for example only.

For more information, refer to the *Audi Engine Management Systems SSP #941003*, page 22.

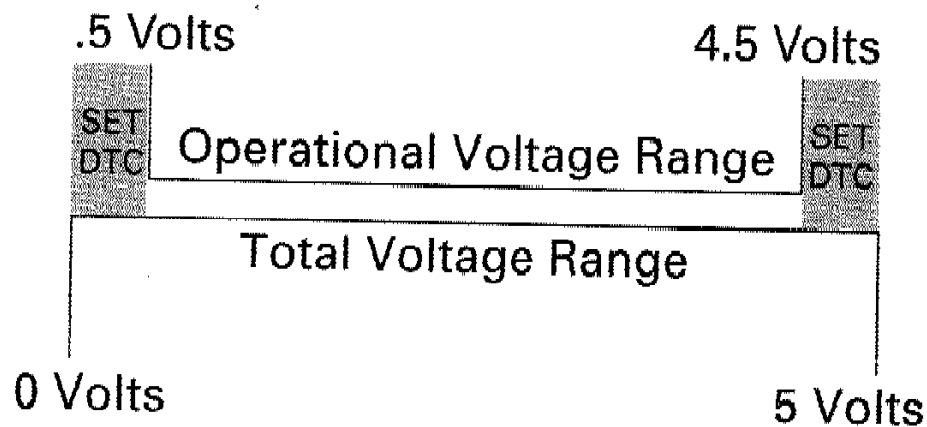

Fault Generation

Component Monitoring Exercise

In this exercise you will build the circuitry for three types of sensors and actuators:

- NTC sensor (engine coolant temperature)
- Potentiometer (throttle position)
- Solenoid valve (fuel injector)

Materials needed:

- Breadboard
- Bag of components and hardware
- Styrofoam cup with hot water
- Multimeter

NTC (2-wire sensor)

In the case of a two wire NTC sensor, the self-diagnosis circuitry measures the returned reference voltage from the sensor.

The Engine Coolant Temperature (ECT) is an example of an NTC sensor. As the temperature at the sensor increases, the internal resistance of the sensor decreases. As a result, the voltage drop across the sensor also decreases.

NTC Sensor Circuit

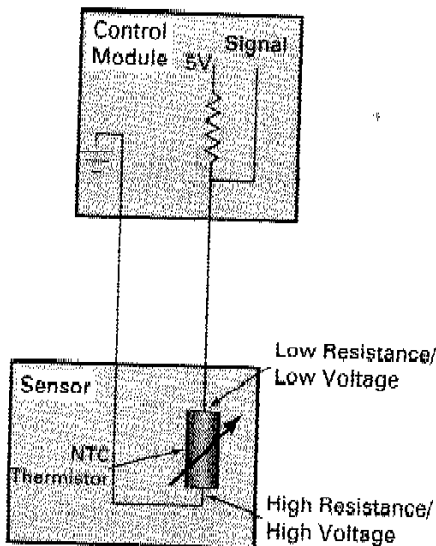

Refer to the schematic diagram projected by the instructor in the classroom. Build the normally operating circuit shown at bottom, left.

At ambient or room temperature, what is the voltage drop across the sensor? _____

Dip sensor in a cup of hot water. What is the voltage drop across the sensor? _____

When the ECM measures a voltage above 4.5 Volts, it is identified as an implausible signal. Because of the high voltage input, the ECM sees this as either an open circuit or a short circuit to battery positive. A "High Input" DTC is set.

Open NTC Sensor Circuit

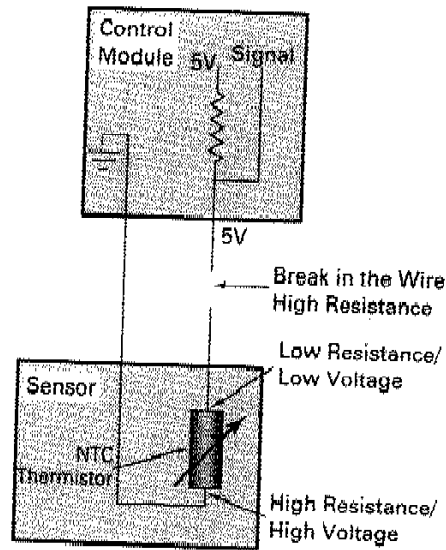

After opening circuit, what is the voltage drop across the circuit? _____

Fault Generation

When the ECM measures a voltage below 200 mV, it is also identified as an implausible signal. Because of the low voltage input, the ECM sees this as either a short circuit to ground, or a low input voltage. A "Low Input" DTC is set.

Shorted NTC Sensor Circuit

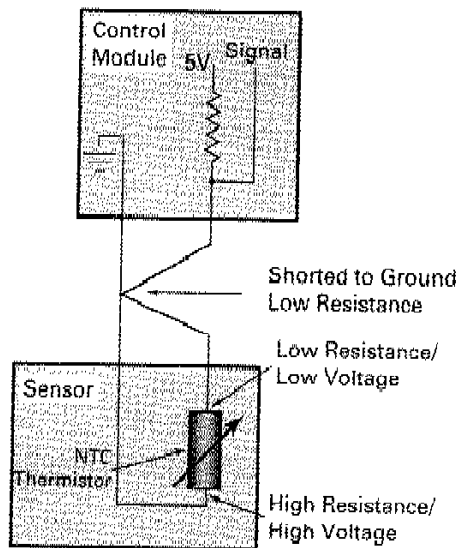

After shorting the ECT sensor, what is the voltage drop across the circuit? _____

Potentiometer (3-wire sensor)

In the case of a three-wire potentiometer, the first wire is the voltage drop across the variable resistance sent to the ECM, the second wire is Ground, and the third is a reference voltage.

The throttle position sensor is an example of a three-wire potentiometer. As the throttle opens, the resistance varies, causing the resistance to change.

Refer to the schematic diagram projected by the instructor in the classroom. Build this normally operating potentiometer circuit.

What is the voltage drop across pins 1 and 2 on the potentiometer? _____

Three-wire Sensor

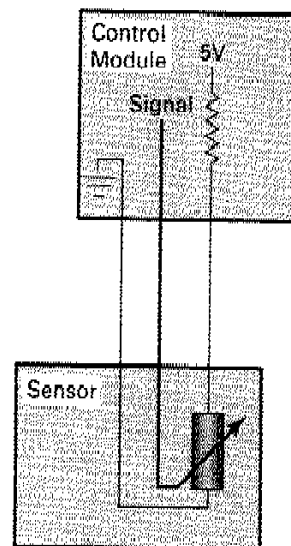

Fault Generation

When the ECM measures a voltage below 200 mV, it is also identified as an implausible signal. Because of the low voltage input, the ECM sees this as either a short circuit to ground, or a low input voltage. A "Low Input" DTC is set.

When the ECM measures a voltage above 4.5 Volts, it is identified as an implausible signal. Because of the high voltage input, the ECM sees this as either a short circuit to battery positive or loss of Ground. A "High Input" DTC is set.

Short to Ground

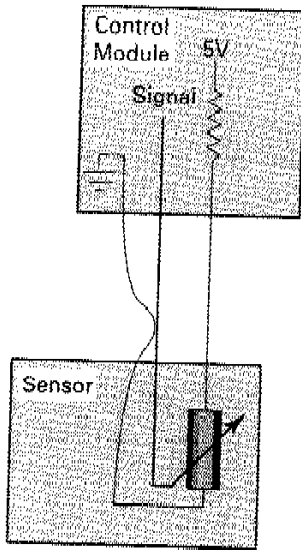

Loss of Ground

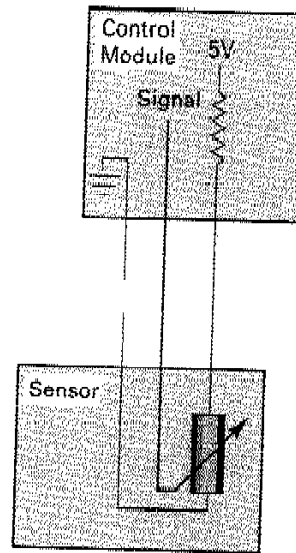

Short to Power

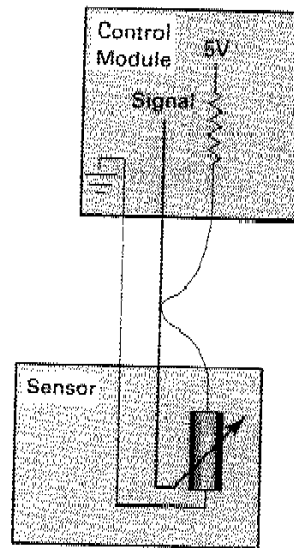

Short pins 1 and 2 together. What is the voltage drop across pin 2 on the potentiometer and Ground? _____

Open the circuit at pin 3 of the potentiometer. What is the voltage drop across pins 1 and 2 of the potentiometer? _____

Open the circuit at pin 1 of the potentiometer. What is the voltage drop across pin 2 of the potentiometer and Ground? _____

Fault Generation

Output circuit (actuators) monitoring

The fuel injector circuit or actuator receives power typically from a relay or fuse. The ECM supplies the Ground that turns the actuator on.

The ECM detects faults internally by monitoring the voltage drop of the actuators on and off cycles with self diagnosis circuitry within the ECM. When the injector is not energized, the ECM expects to see supply voltage at output stage circuit inside the ECM.

When the ECM closes the Ground circuit, the ECM expects to see a voltage drop between 0.2 and 0.8 Volts. If the wrong voltage is measured, a DTC will be set.

A fuel injector is an example of an output actuator.

Refer to the schematic diagram projected by the instructor in the classroom. Build this normally operating actuator circuit.

With the switch open, what is the voltage drop across the switch? _____

With the switch closed, what is the voltage drop across the switch? _____

Open the switch. Disconnect wire from the fuse to the fuel injector (open circuit). What is the voltage drop across the switch? _____

Close the switch. What is the voltage drop across the switch? _____

Short circuit the switch with the switch open. What is the voltage drop across the switch? _____

Reconnect the wire from the fuse to the fuel injector. Keep short across switch. What is the voltage drop across the switch? _____

Summary

The ECM monitors both sensors and actuators, continually measuring the voltage drop across the components. If the voltage drop is incorrect for the given operating conditions, a DTC is set.

Output Monitor Circuit

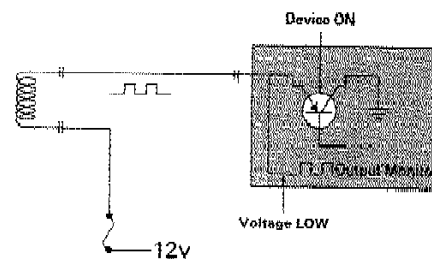
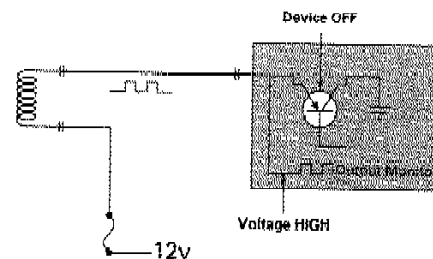
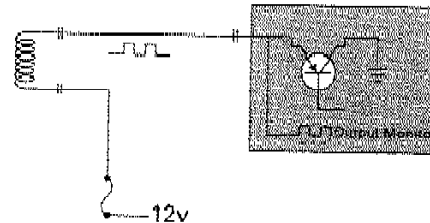

Fuel Delivery

Learning Objectives:

- After being instructed in class how to safely and effectively test fuel pressure and volume, the technician will, given the required tools (VAS 5051, VAG 1318 fuel pressure gauge w/ adapters, VAG 1602 graduated cylinders) and vehicle, perform fuel psi and volume tests on a vehicle, and document all measurements.

Fuel pressure and volume

It is critical that the fuel system can consistently provide fuel in the correct quantity and pressure.

When a vehicle exhibits driveability problems, fuel pressure and volume tests must be performed to identify the condition of the fuel system. These tests include:

- Fuel delivery volume test (rate checking)
- Fuel pressure test
- Residual pressure test
- Injector leakage test
- Injector quantity test
- Current draw test
- Current draw test for fuel pump

What kinds of symptoms may indicate that a fuel system test should be performed?

- driveability problems
- hard or no starting (hot and cold)
- misfire
- current draw
- stalling
- cutout
- adaptation problems

Example of fuel volume vs. pump voltage

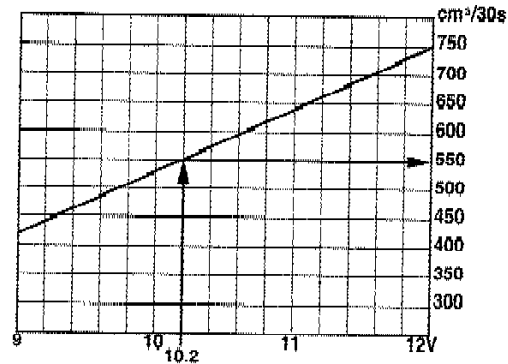

Note:

Always refer to the latest repair information for specifications.

Affects of fuel pressure on system adaptation

The engine management system uses the feedback from various sensors (including the oxygen sensor) to adjust the injector pulse duration for optimum mixture formation. If the fuel system is not functioning correctly, the engine management system attempts to adapt to these conditions. If the malfunction is minor, the system will adapt, and operation will not be affected. If the malfunction is major, the adaptation could exceed adaptation limits and cause a DTC to be stored in memory. The engine management system will then attempt to protect the engine by defaulting to pre-programmed values (emergency running mode).

Some possible problems can include a blocked fuel filter, malfunctioning fuel pump, clogged fuel tank vent line, malfunctioning or clogged fuel injector, and malfunctioning fuel pressure regulator.

Fuel Delivery Quiz

Fuel Delivery Quiz

The following questions apply to a m.y. 2000 Audi A4 with the 1.8 T engine.

1. Voltage to the Motronic System fuel pump is supplied by:
 - A. The Engine Control Module
 - B. The ignition switch
 - C. The fuel pump relay
 - D. The load reduction relay
2. When installing the fuel delivery unit in the fuel tank, the flange seal:
 - A. Should be coated with engine oil to ease assembly.
 - B. Should be installed dry to prevent shifting of the seal.
 - C. Should be lubricated with gasoline.
 - D. Should always be replaced.
3. All of the following tasks must be performed to check fuel delivery EXCEPT:
 - A. Measure battery voltage
 - B. Engine must be at operating temperature.
 - C. Disconnect the vacuum line from the fuel pressure regulator.
 - D. Connect a remote control switch in the fuel pump circuit.
4. If the fuel delivery rate test shows a low delivery rate when tested at the fuel line connection in the engine compartment, what should you do?
 - A. Replace the fuel pump.
 - B. Check the delivery rate before the fuel filter.
 - C. Check the fuel pressure.
 - D. Perform an injector quantity test.
5. Which of the following DTCs could suggest the need for a fuel pressure and volume test?
 - A. Both C and D.
 - B. Oxygen sensor no signal.
 - C. Fuel system too rich.
 - D. Fuel system too lean.
6. The vehicle fails a residual fuel pressure test. Technician A says that the fuel pressure regulator could be faulty. Technician B says that the fuel pump check valve could be leaking. Who is right?
 - A. Technician A only
 - B. Technician B only
 - C. Both technician A and B
 - D. Neither technician A nor B

Fuel Delivery Quiz

7. A fuel injector quantity test can be used to locate the causes of all of the following conditions EXCEPT:
- A. Lean mixture problems
 - B. Engine misfire problems
 - C. Low engine performance problems
 - D. Oxygen sensor problems
8. A 2000 A4 is experiencing leakdown during a residual fuel pressure test. The technician notices that one injector drips fuel at a rate of one drop every two minutes. What should be done?
- A. The injector should be replaced.
 - B. The search for the drop in residual pressure should focus elsewhere.
 - C. Substitute the injector with a known good component and perform the test again.
 - D. Replace the fuel pressure regulator.
9. How are the injectors activated when conducting a fuel injector quantity test?
- A. Using a remote control switch hooked up between the battery and the injector.
 - B. Using the Output state test with VAG 1551.
 - C. Ground one terminal of the injector.
 - D. Both A and C.
10. Fuel pressure drops during a residual fuel pressure test after the fuel return line is pinched shut. Technician A says that the fuel injectors should be checked for leaks. Technician B says that the fuel pressure regulator is leaking. Who is right?
- A. Technician A only
 - B. Technician B only
 - C. Both Technician A and B
 - D. Neither Technician A nor B

Notes

Fuel Delivery Answer Sheet

Audi Engine Management Systems, Level One
Course # 941002
Fuel Delivery Quiz Answer Sheet

Name: _____ **Date:** _____

Record the answers to the questions by blackening the letter of your choice for each question.
Fill in blanks where appropriate.
DO NOT CIRCLE THE LETTERS!

1. A B C D
2. A B C D
3. A B C D
4. A B C D
5. A B C D
6. A B C D
7. A B C D
8. A B C D
9. A B C D
10. A B C D



Ignition System

Learning Objectives:

- The technician will be able to identify and diagnose the two common ignition systems used in Audi vehicles.

System descriptions

The 2.8 5V V6 use double ended (waste spark) coils, and the 1.8T and V8 engines use a single coil for each cylinder (spark plug mounted). Both systems are distributorless, have cylinder selective knock control, and the ground signal is controlled by the ECM.

Ignition system components include:

- Power output stage
- Double ended (waste spark) ignition coils
- ECM
- Ignition wires

Waste spark ignition system

Each ignition coil supplies spark to two spark plugs. One spark plug fires during the compression stroke, the other fires during the exhaust stroke (waste spark).

The Motronic ECM operates each double-ended ignition coil via the Power output stage (Power stage). The Power stage, along with the heat sink, is attached to the ignition coils. (As of model year 2000, Audi no longer uses an external power output stage).

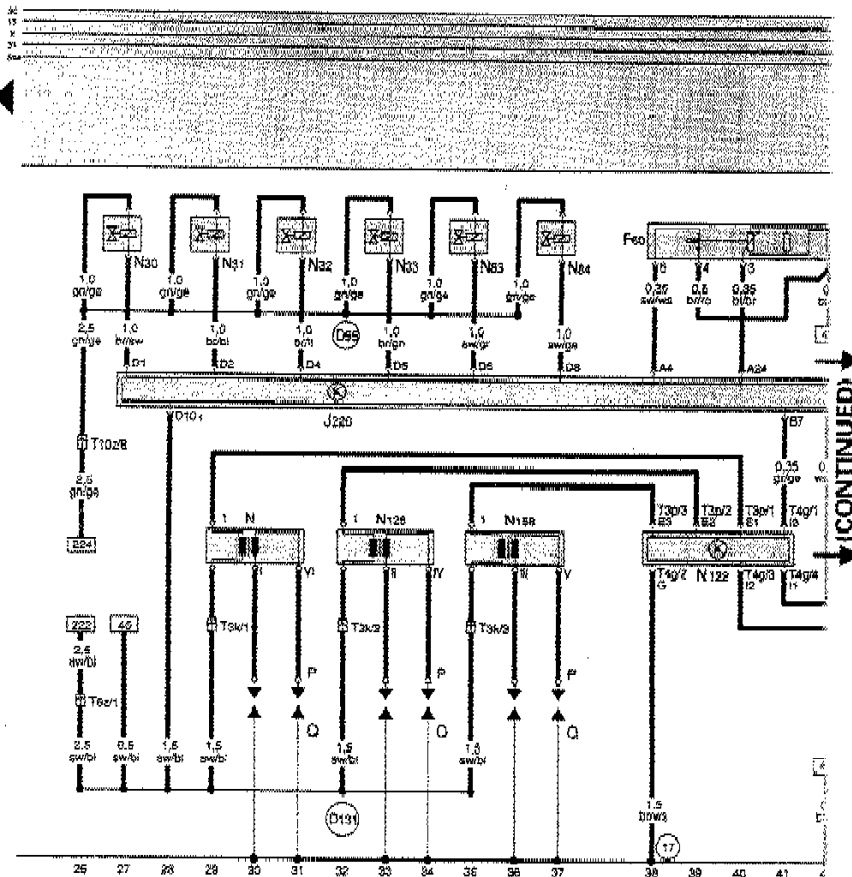

Ignition System

1.8 Turbo

Due to the increase in combustion pressure individual coils are used. Each cylinder has its own:

- Spark plug mounted coil assemblies
- Power output stage integral with coils
- ECM spark plug with resistor connector

System troubleshooting

There is no direct monitoring of the primary or secondary ignition circuits by the ECM for fault recognition. Therefore, it is critical that the technician understand the function of the ignition system, and the influence it can have on the engine management system.

When troubleshooting the ignition system, focus is on the primary and secondary circuits.

Primary circuit

- Power
- Ground
- Trigger signal

Secondary circuit

- Secondary coil winding resistance
- Secondary ignition wire resistance

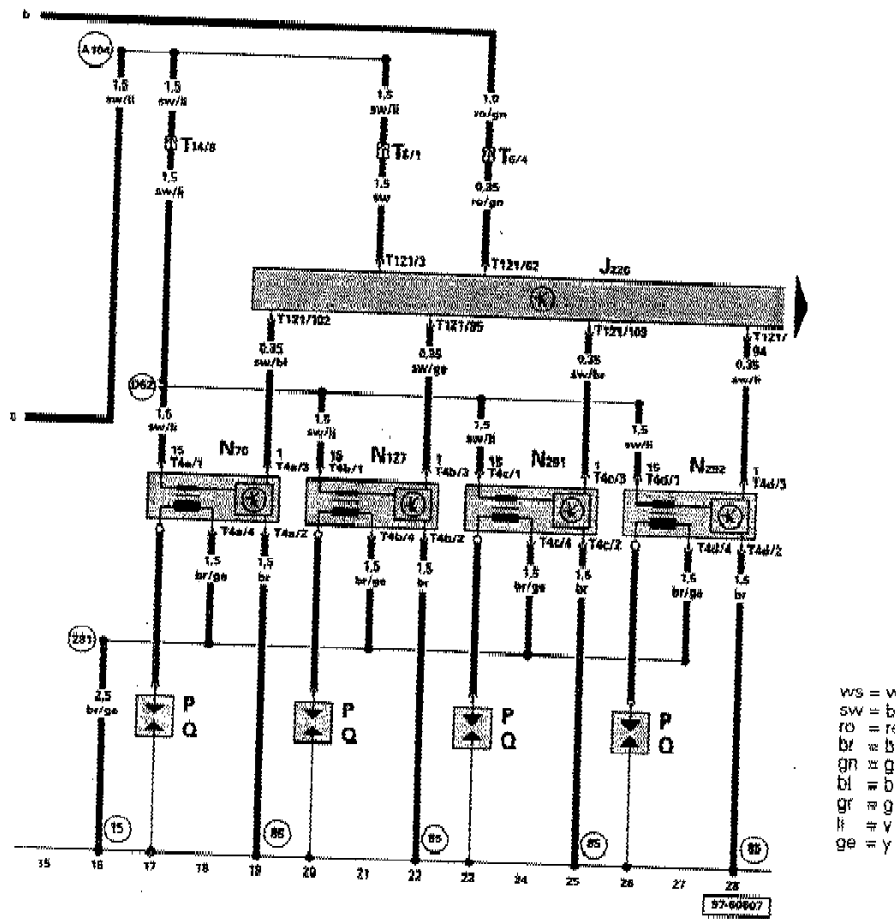

Mixture Control

Learning Objectives:

- After participating in an instructor led demonstration of oxygen sensor monitoring using the DSO, the technician will be able to interpret oxygen sensor signals and their effect on emissions.

As previously discussed, the engine management system controls the air/fuel mixture based on inputs from various sensors, including the oxygen sensor.

The engine management system uses these inputs to maintain the mixture within the Lambda window. If there is a change in operating condition for either fuel or air, the Motronic ECM modifies the actuators accordingly.

Oxygen Sensor Voltage vs. Air/Fuel Ratio

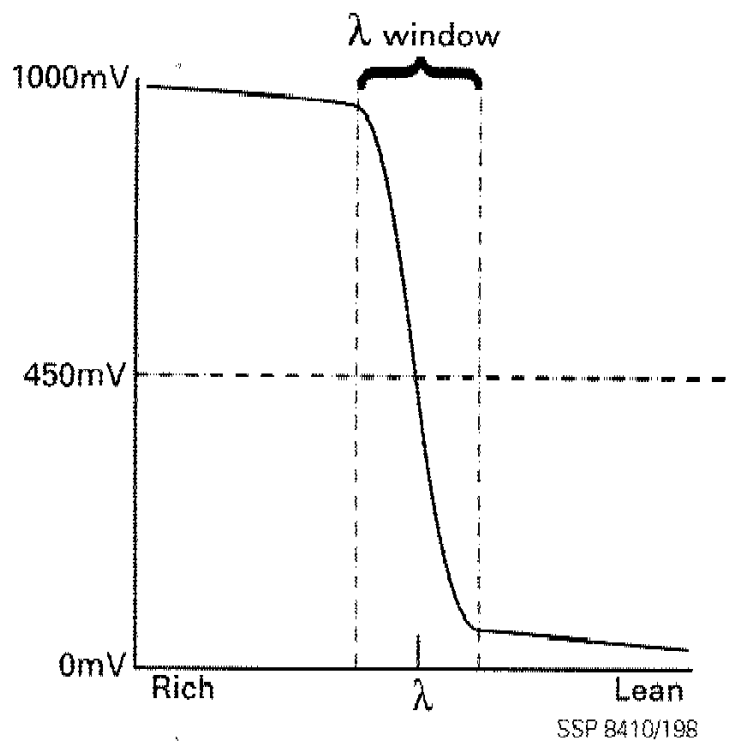

Mixture Control Notes

(This section contains horizontal lines for handwritten notes.)

Measuring Value Blocks

Learning Objectives:

- This exercise will introduce the technician to troubleshooting using 4 field display groups.

4 field display groups

Function 08 of the scan tool allows the technician to view operating parameters and associated signals of the control module. This allows the technician to view any influences on the function of the system in real time.

This function is a necessary tool for diagnosing DTCs in any engine management system.

Depending on the control module, there can be up to 140 measuring value blocks, each displaying up to 4 windows of information. Often times the information can be viewed in several different windows. Groups are laid out to include associated information together.

Example:

Often times viewing engine load (MAF) and injector duration may need to be done together. Engine load may also be shown in a different group with the oxygen sensor output. This allows for the viewing of pertinent data without having to navigate to a different group.

AESIS documents each group along with the specified values for each window. This allows the technician to compare the reading on the scan tool with the correct value. Many of these values are displayed in a scale of 0-255, with 128 being the mid-point.

The illustration below is an example of a 4 field display group, with callouts describing the function of each section of the table.

The "Indicated" row describes how the information will be displayed.

The row designated as "Range" provides minimum and maximum parameters obtainable.

Display Fields				
	1	2	3	4
Display Group 34: Oxygen sensor aging (time period of oxygen sensor)				
Display	xxxx RPM	xx.xx ms	x.xx s	text
Indicated	Engine speed (increments of 40 RPM)	Engine load	Time period of heated oxygen sensor (HO2S) before TWC	Diagnostic status Diagnostic result
Range	0 to 6800 RPM	0.00 to 8.50 ms	0.00 to 5.00 s	Test OFF / Test ON / B1-S1 OK B1-S1 n.OK
Specified value to perform FC	1800 to 2200 RPM	0.80 to 2.00 ms	0.00 to 3.30 s	B1-S1 OK

The "Specified Value" row contains the conditional information required to achieve a B1-S1 OK status.

Display Group 000

Learning Objectives:

- Given the VAS 5051 and a "bugged" test vehicle, the technician will call up measuring value block 000 and demonstrate/document how multiple value blocks (10 fields) relate to the problem.

Display group 000

Display group 000 differs from the Measuring Value Blocks. Instead of displaying 4 fields, MVB 000 displays 10 fields.

This group is extremely useful in diagnosing adaptation faults. Adaptation values for Long term, Short term, and Idle adaptation are shown, along with key engine management components.

This field, if read properly, can tell a technician immediately where an adaptation fault is having the largest effect on the system. This can narrow down the diagnosis substantially.

Note:

Display group 000 varies with model year and vehicle mode. Always consult AESIS for the correct information.

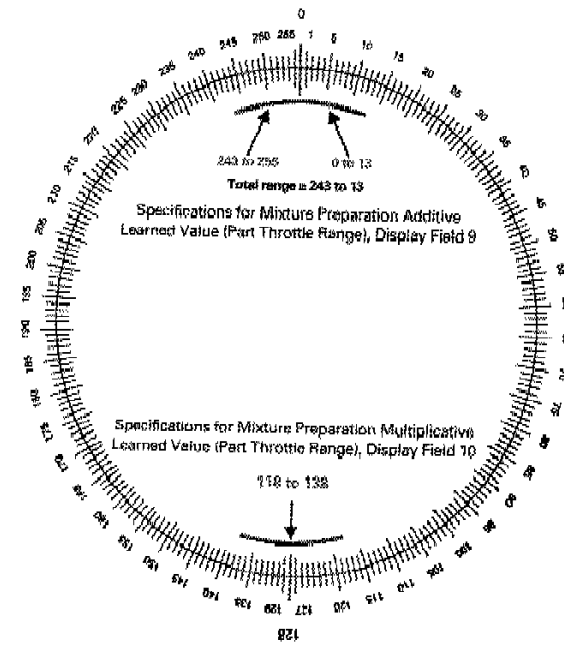

Display group 000 (decimal displayed value) 1.9L Turbo DSD-II									
• Engine idling									
Read measuring value block 0 ← indicated on display									
X	X	X	X	X	X	X	X	X	X
1	2	3	4	5	6	7	8	9	10
← Display zones									
				Mixture preparation multiplicative learned value (part throttle range)		Specification		Corresponds to	
						118 to 138		- 6 to 8%	
				Mixture preparation additive learned value (part throttle range)		243 to 255		- 0.04 to 0.06 min	
				Oxygen sensor control		77 to 179		-10 to 10%	
				Idle Air Control learned value		128 to 138		-4 to 4 Kg/h	
				Idle Air Control		120 to 138		-4 to 4 Kg/h	
				Throttle valve angle		9 to 12		3 to 5	
				Engine Control Module supply voltage		170 to 206		12 to 14.5 Volts	
				Engine speed (Idle speed)		82 to 90		820 to 900 rpm	
				Engine load		10 to 40		0.5 to 2.0 ms	
				Engine coolant temperature		170 to 204		88 to 100 °C	

Display Group 000 Quiz

Measuring Value Block, Display Group 000

Use the chart on the previous page to answer the questions below:

- When would Display Group 000 be most helpful in diagnosing a problem in the engine management system?
 - When there is a "high input" DTC for a sensor.
 - When there is an engine performance problem with no DTC recorded.
 - When a DTC for "Adaptation Limit Exceeded" is set.
 - Both B and C.
- On the 1.8 liter A4, display field 6 displays 110 and display field 7 displays 105. What does this mean?
 - The air conditioner has been left on.
 - The air filter is very dirty.
 - There is a vacuum leak somewhere in the intake after the throttle valve.
 - The intake air duct has become disconnected from the throttle control valve.
- Which of the following values would you expect to see in display field 8 if the Oxygen Sensor was leaning out the mixture?
 - 72
 - 199
 - 128
 - 241
- Which of the following values would be in specification for display field 9?
 - 241
 - 2
 - 12
 - 15
- Display field 8 reads 128. The value does not fluctuate. What does this mean?
 - The ECM does not have to adapt mixtures for either an excess of air or fuel.
 - The Oxygen Sensor control has been blocked.
 - The Oxygen Sensor is adjusting for a rich mixture.
 - The Oxygen Sensor is adjusting for a lean mixture.
- Display field 1 reads 118. Technician A says the engine is at operating temperature and display group values should be printed for evaluation. Technician B says the engine is overheating. Who is right?
 - Technician A only
 - Technician B only
 - Both Technicians A and B
 - Neither Technician A nor B

Display Group 000 Quiz

7. Which of the following conditions could cause display field 5 to read 16 at idle?
- A. Accelerator cable misadjusted.
 - B. Throttle valve stuck.
 - C. Throttle valve potentiometer malfunctioning.
 - D. All of the above.
8. Which of the following display fields would show the effects of an automatic transmission that was in a driving range (not Park or Neutral)?
- A. Display field 2
 - B. Display field 3
 - C. Display field 6
 - D. Display fields 2 and 3
9. Where is information for display group 000 found in AESIS?
- A. Repair Group 01 in the Fuel Injection and Ignition section
 - B. In the General, Engine section
 - C. In Repair Group 24
 - D. In Repair Group 20
10. What is the first thing to do if display field 3 is not within 82-90?
- A. Check the Throttle Valve Control Module.
 - B. Check intake air system for leaks.
 - C. Perform idle speed check.
 - D. All of the above.

Display Group 000 Answer Sheet

Audi Engine Management Systems, Level One
Course # 941002
Display Group 000 Quiz Answer Sheet

Name: _____ **Date:** _____

Record the answers to the questions by blackening the letter of your choice for each question.
Fill in blanks where appropriate.
DO NOT CIRCLE THE LETTERS!

1. A B C D
2. A B C D
3. A B C D
4. A B C D
5. A B C D
6. A B C D
7. A B C D
8. A B C D
9. A B C D
10. A B C D



Emissions Systems

Learning Objectives:

- After viewing the EVAP video and an instructor-led demonstration on a vehicle with an intact EVAP system and one with a leak, the technician will explain how to diagnose an EVAP system leak.
- Given an EVAP video, ESIS, hand tools, test equipment, and a vehicle with an evaporative emissions problem that lights the MIL, the technician will find the problem and document the test steps to the instructor's satisfaction.

Emissions systems overview

This section is designed to reinforce the emissions systems section of the Engine Management SSP by including diagnosis. The emissions system will be separated into three groups:

- Evaporative Emissions (EVAP)
- Secondary Air Injection
- Three-way Catalytic Converter
- Positive Crankcase Ventilation (PCV)

Evaporative Emissions (EVAP)

Evaporative Emissions includes Leak Detection Pump (LDP) and On-Board Refueling Vapor Recovery (ORVR) systems.

The illustration below identifies all the components of the EVAP system.

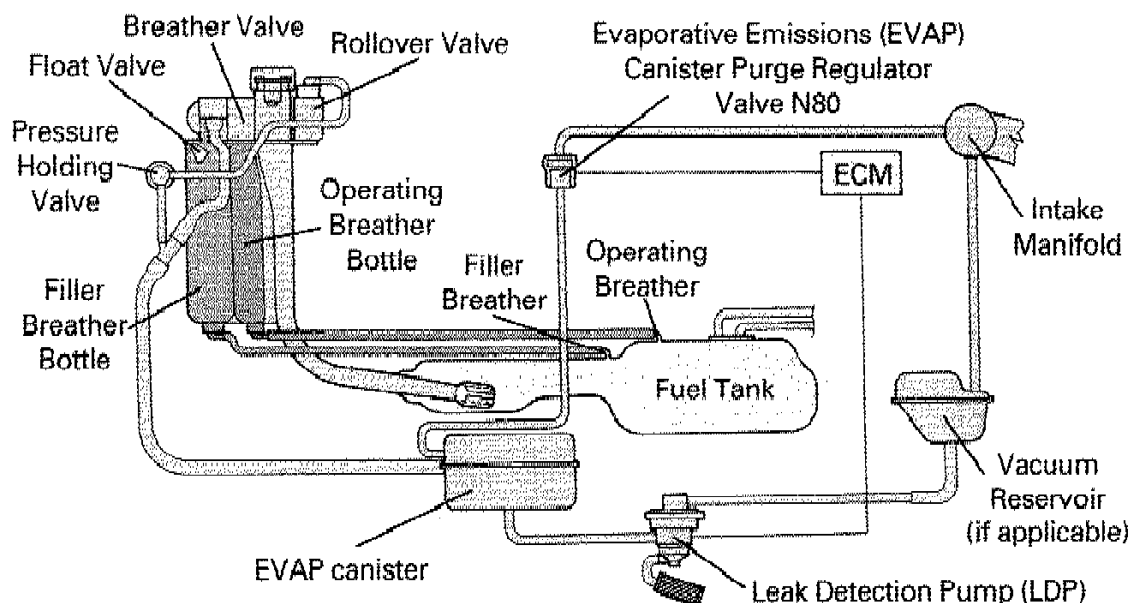

Emissions Systems

Secondary Air Injection (AIR)

After a cold start (engine in open loop mode), the secondary air injection system adds extra air into the exhaust stream just past the exhaust valves to aid in the afterburning of combustion gases.

Components of the Secondary Air (AIR) system include the Secondary Air Injection (AIR) solenoid valve N112, pump motor V101, and pump relay J299.

The system not only provides for a quicker warm-up for the three-way catalytic converter, but it improves driveability and reduces exhaust emissions.

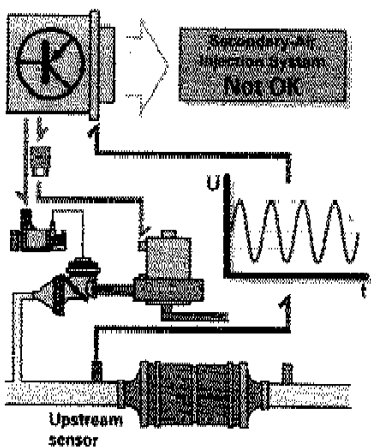
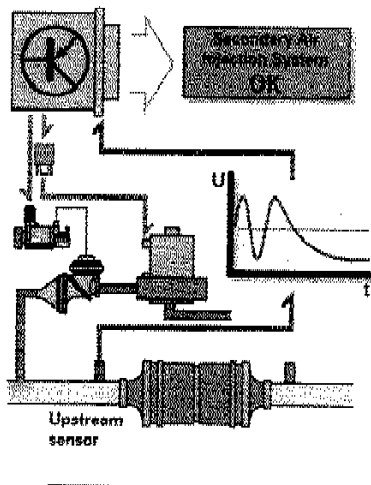

Three-way Catalytic Converter

A Three-Way Catalytic (TWC) converter is so named because it takes the three major exhaust pollutants and changes them through reduction and oxidation. The pollutants are:

- NO_x (Oxides of Nitrogen)
- HC (Hydrocarbons)
- CO (Carbon Monoxide)

The output from a normally operating TWC consists primarily of:

- N₂ (Nitrogen)
- CO₂ (Carbon Dioxide)
- H₂O (Water)

The workshop exercises are designed to demonstrate the functionality of the Three-Way Catalytic (TWC) using the 5-gas Analyzer to monitor exhaust emissions.

Readiness Code

Readiness Code

After checking and erasing a DTC, the readiness code must be set to verify the repair.

The readiness code is a series of internal test procedures that are performed by the engine control module.

The readiness code is displayed in an 8-bit binary code format, with each bit containing specific information relating to a monitor. A binary code of "1" indicates a completed test, while a binary code of "0" indicates that the system has passed, or the vehicle is not equipped with that system.

Example of readiness code:

Setting the readiness code

The readiness code can be accomplished by completing a driving cycle, or "long trip," in which all systems are monitored and no additional failures are detected. Since this is impractical for the workshop technician, the "short trip" method was created. The short trip enables the technician to set the readiness code (using the scan tool) in a reasonable period of time by selectively running the diagnostic routines for specific systems under the proper condition.

The Readiness Code is generated only when all display fields show 0								
1	2	3	4	5	6	7	8	Diagnostic Function
							0	Catalyst
							0	Catalyst heating (not installed / always "0")
						0		Activated charcoal filter system (tank venting system)
				0				Secondary air system (not installed / always "0")
			0					A/C (currently, no diagnosis / always "0")
		0						Oxygen sensors
	0							Oxygen sensors heating
0								Exhaust Gas Recirculation (EGR) system (not installed / always "0")

Readiness Code

The following is an example detailing the steps needed to set the readiness code in a 2.8 Liter 5V V6. Read through the steps listed.

In the workshop, look up vehicle specific information in AESIS and perform the readiness code procedure worksheet using the scan tool.

Quick Reference: How to Set Readiness Code 8 Cyl. 4.2 ltr. MY 2000

No	Diagnostic Status	Engine Condition	Procedure: V.A.C. TEST - Settings after successful Diagnostic				
			Function Display/Comp	Channel 1	Channel 2	Channel 3	Channel 4
1	Check DTC Memory	Engine OFF	02				
2	Clear DTC Memory	Ignition ON	05				
3	Adaptation Throttle Valve Control Module	Engine OFF Ignition ON	04/060	10% - 20%	80% - 90%	0 - 8	ADP.OK
4	Adaptation Kick Down only AG	Engine OFF Ignition ON	04/063	12% - 92%	2% - 47%	Kick Down	ADP.OK
5	Fuel System Leakage Check	Engine ON Idle	04/071			Check END	Syst. OK
6	EVAP Canister Purge Regulator Valve Check	Engine ON Idle	04/070	0% - 100%			EVAP OK
7	Lambda Control	Engine ON Idle	04/107	650 - 730 RPM	-10% - +10%	-10% - +10%	Syst. OK
8	Heated Oxygen Sensor ***	Engine ON 1800...2200/min**	04/041 04/042	0 - 0.9 kOhm	Htg. bC ON	0 - 0.9 kOhm	Htg.bC ON
9	Operational Readiness of Oxygen Sen. behind Cat. Conv.	Engine ON Idle	04/036	0V - 1V	B1-S1 OK	0V - 1V	B2-S1 OK
10	Response Time Front Heated Oxygen Sensor	Engine ON Idle	04/034 04/035	650 - 730 RPM	more than 20°C	0.1 - 1.0s	B1-S1 OK B2-S1 OK
11	Oxygen Sensor Control System	Engine ON Idle	04/037 04/038	11.5% - 21.5%	0.1V - 1.0V	-800ms - +800ms	Syst. OK
12	Oxygen Sensor aging behind Cat. Conv.	Engine ON Idle	04/043 04/044	650 - 730 RPM	more than 20°C	0 - 1V	B1-S1 OK B2-S1 OK
13	Three Way Catalytic Converter	Engine ON 1900...2400/min**	04/045 04/047	1700...2400 RPM**	more than 20°C	0 - 0.25	CAT B1 OK CAT B2 OK
14	Secondary Air System	Engine ON 1800...2400/min**	04/077 04/078	1800 - 2400 RPM**	more than 13 g/s	-70 - +30%	Syst. OK
15	Check Readiness Code Setting	Engine ON Idle	03/086	00000000	00000000	00000000	00000000

Requirement: Coolant Temperature more than 80°C (09/001/2)
 * to warm up engine if necessary, test is complete when values are present in channel 1 and 3
 ** only during Diagnostic Performance

For more details, refer to Repair Manual "Readiness Code" chapter.

Use the Scroll Up and Scroll Down buttons to view the rest of this page.

Scroll Down Scroll Up

Readiness Code Worksheet

Learning Objectives:

- After participating in a classroom discussion on how the readiness code and the short trip monitor can be used for diagnosis, the technician will use the VAS 5051 to set the readiness code on a vehicle and diagnose system faults to the instructor's satisfaction.

Readiness code exercise

What vehicle/engine type are you working on? _____

Record the readiness code.

--	--	--	--	--	--	--	--

Record the data from each display field during all steps of the readiness code procedure.

1.				
2.				
3.				
4.				
5.				
6.				
7.				
8.				
9.				
10.				
11.				
12.				
13.				
14.				
15.				
16.				
17.				
18.				
19.				
20.				

Turbocharger System

Learning Objectives:

- After participating in a classroom discussion regarding turbocharger operation, controls, and testing, the technician will be able to complete a shop exercise on monitoring the turbocharger system using the VAS 5051 and VAG 1397A turbocharger tester to the instructor's satisfaction.

Turbocharger operation

Exhaust gases leave the combustion chamber under great pressure and releases energy into the exhaust system. This normally wasted energy drives the impeller on the compressor side of the turbocharger, acting as a pump to pressurize the air required for combustion. This causes the volume of air entering the cylinders per cycle to increase.

Air temperature is increased by compression, but reduced again in the charge air inter-cooler. Cool air has a higher density, so the air/fuel mixture entering the engine is greater also. This results in an increase in power output for the same displacement and engine speed.

In the case of the 1.8 liter, 5-valve engine, turbocharging is also used to provide high torque in all RPM ranges. Charge pressure increases in proportion to turbocharger speed. To prolong the life of the engine, the pressure is limited by the charge pressure control system.

For the system to operate properly, charge air pressure control is used to maximize efficiency at all times, as well as limit overall charge pressure.

Components of the charge pressure control system include:

- Motronic ECM J220
- Wastegate bypass regulator valve N75
- Charge air pressure sensor G31 Air charge is recirculated to enhance the efficiency of the turbocharger during light loads and deceleration.

Recirculation components include:

- Motronic ECM J220
- Air recirculation valve N249
- The charge pressure control system prevents the turbocharger from slowing down unnecessarily if the valve closes suddenly. Maintaining high turbocharger speed in this circumstance allows it to deliver power quickly and without turbo "lag."

